

KERSTEN

Instruction and Parts Manual

K2000 and K2000/E



Part no 6000 000 001 Copyright Kersten (UK) Ltd © 2008

Compiled 28/04/08

UK

Kersten Maschinenvertriebs GmbH
D - 46459 Rees, Empeler Straße 93-95
www.kersten-maschinen.de
Tel.: 028 51 / 92 34 0
Fax: 028 51 / 92 34 44

Kersten (UK) Ltd
Progress House, 39 Boulton Road
Reading, Berkshire RG2 0NH

Phone: 0118 986 9253
Email: info@cnect2.com

CONTENTS

1.	About this Manual	4
1.1	Product Identification	4
1.2	Before Start Up	4
1.3	Intended Use	5
2.	Safety Precautions	5
2.1	Transporting	6
2.2	Safety	7
3.	Basic Rules	8
3.1	Before Starting	8
3.2	Repair Work	8
3.3	General Maintenance	9
4.	Disposal	9
5	Warrenty	9
6.	Assembly	10-13
7.	Operation	14-15
8.	Maintenance	16-17
9.	Technical Data	18
10.	Conformity	19
11.	Parts Lists	20-33

1 About this manual

Dear Customer,

We thank you for the purchase of this machine or attachment and having confidence in our equipment.

Before using this machine please read this instruction manual carefully.

Keep this manual to hand as it contains important information and instructions.

The machine or the attachment is subject technical progress.

All Information, illustrations and technical data corresponds to the newest model at the time of the publication.

Changes due to technical progress are reserved by the manufacturer at any time.

1.1 Product Identification

Always quote model number and serial number when ordering spare parts.

The identification plate may be found on the main chassis of all machines.



1.2 Before start up

We are not liable for any substantial accident and/or damage.

Before you drive this machine or start the engine of the Kersten machine that you are handling, we ask that you urgently to make yourself familiar with this manual and the operation of the machine.



- **This symbol indicates important safety information!**
- **Read all safety references on the following pages!**
- **Read the operating instructions before start-up!**
- **Use this manual in conjunction with the power unit manual!**
- **Pass all safety instructions onto other users!**

1.3 Intended use



- The machine is a hydraulically propelled 2 wheel tractor exclusively intended for professional employment in the management of land, forestry, amenity and landscape conservation and for sole use with Kersten attachments. (Also see individual attachment instructions.)
- Use going beyond that described is not considered as intended. Therefore the manufacturer is not responsible for any resulting damage or harm and the operator alone is responsible for the risk.
- Compliance with and adherence to the operating, maintenance and repair as prescribed by the manufacturer in this manual must be considered essential elements of intended use.
- The machine may only be operated repaired and serviced by persons familiar with the machine, this manual and all relevant safety features and dangers.
- The relevant rules for the prevention of accidents as well as other safety-relevant rules according to the health and safety at work act must be considered as part of the operating procedure.
- The manufacturer is not liable for any accidents or damage resulting from modifications or alterations carried out on the machine without the express written permission of the manufacturer.

2 Safety Precautions

It is important to note that not all possibilities can be covered within this manual.

The manual assumes that the operator has a general awareness for Health and Safety to be appointed an operator in the first place.

This Kersten machine has been designed, so far as is reasonably practical, so that it will not endanger the safety of the operator or anyone else if the machine is used and maintained according to the instructions stated in this manual which have been compiled following research and experience of the manufacturers.

General safety and accident prevention instructions:



- Consider all additional valid general operating instructions and health and safety regulations
- This machine should not be operated by any person under the age of 16.
- This machine may be subject to regulations when used on the public highway
- Before starting operating this machine you should be familiar with all controls and their functions. Familiarization should not be carried out during operation.
- The user is responsible for operating the unit in the work area.
- Standing in the danger area of the machine is forbidden!
- Look out for any children or animals in the work area.
- Operators are advised to wear clothing that is close fitting with stout footwear. Loose fitted clothes or casual footwear increase risk of accident



- All controls, engine and functions must be cleaned regularly.
- Do not leave the engine running in an enclosed area.
- Whenever handling fuel there is an increased risk of fire. Never refill near a naked flame or sparks, do not smoke whilst refilling the fuel tank.
- Before refuelling, turn the engine off, allow to cool down and take ignition keys out (if available).



- Keep machine clean to reduce the risk of fire
- When starting the engine all drives must be switched off
- Never leave the operator console while driving
- Never adjust the handlebar while engine is running
- Never leave the machine whilst engine is running.
- Close the fuel valve when machine is not in use.
- Apply parking brake (where fitted), when leaving, and minimize unauthorized use!
- Never leave the equipment unsupervised, when the engine is running.

2.1 Transporting

When transporting this unit ensure all possible power is isolated disengaged and disabled.

Apply parking brake where fitted.

Secure the machine by use of bindings any transporting vehicle.

Only transport on vehicles designed for the use of transporting this type of equipment.

2.2 Safety

Attention! This machine is equipped with warning symbols (safety decals).

Be aware of your safety at all times when operating a machine.

Real security means that you are familiar with all safety decals.

These decals indicate types and areas of endangerment and in particular the safety measure which should be taken.

Always remain alert and conscious of the dangers the decals indicate on the machine, you are operating, presents to you and others.

The decals must be maintained in good condition, they are important safety devices

The following decals are present on this machine:



Read the safety manual carefully before start up.



Before repair, maintenance and cleaning

Turn off engine and pull out keys



Consider references in the technical manual.

Lubrication fitting



The risk by away-hurling parts with running engine.

Respect a safety margin from the

3 Basic Rules



- Always use the machine across the slope in preference to going up and down
- Use extreme caution when changing direction on a slope
- Do not operate this machine on slopes of more than 20 degrees
- Humidity and rain increases the danger of slippage. Certain conditions may not permit safe handling of the machine
- Wear firm footwear with sufficient profile.
- Operate only in conditions where sufficient lighting exists
- Check terrain for hidden hazards prior to commencement of operation
- In the event of accidental impact with a foreign object, immediately stop the machine, including engine, and inspect for damage before continuing
- Never run whilst operating the machine
- Disengage drive to the attachment when transporting machine to and from area to be worked
- Never put hands or feet near or under rotating parts
- Prior to any maintenance or repair work ensure that all drives are in the neutral position, all switches are in the off position and for extra safety the spark plug lead should be removed

3.1 Before starting



- When starting the engine all drives must be disengaged – i.e. all drive leavers should be in the neutral rest position
- Never leave the operating position whilst machine is running
- Do not adjust handle bars when operating
- Do not operate the machine without all guards and safety devices being intact
- Keep hands and feet always from all rotating parts
- In the event of malfunction stop immediately

3.2 Repair work

- Repair work such as a welding, cutting or drilling must not be carried out on any safety relevant parts
- Damaged parts should be replaced with new before further use of the machine

3.3 Maintenance



- Examine the machine before start-up to ensure it is in a safe operating condition, paying particular notice to the security of all screw fittings
- Worn/damaged parts should be replaced as a safety precaution
- Cleaning should be carried out regularly to aid visual inspection of all working parts on the machine, including all safety devices, and to prevent fire hazards
- Cleaning, e.g. with a high pressure cleaner, should be accomplished in such a way that the water jet is not focused directly on rotating parts, lubrication points and electrical fittings.
- The machine should be maintained according to the instructions contained within the manual.
- Failure to comply with maintenance and operating instructions will cause the guarantee to be considered null and void

4 Disposal

This device must be disposed of according to the regulation of the municipality or the country. All possible parts should be recycled and the remainder disposed of in a satisfactory manner.

The company Kersten Maschinenvertriebs GmbH or Kersten (UK) Ltd does not take responsibility of disposal.

5 Warranty

Details of Warranty are included on the warranty registration form.
All conditions must be satisfied.

IMPORTANT! Please complete the warranty registration form enclosed and send it to:

Kersten (UK) Ltd
Progress House, 39 Boulton Road
Reading, Berkshire RG2 0NH

Phone: 0118 986 9253
Email: info@cnect2.com

6. Assembly

6.1 Assembly Dirt collector

Attach left and right hand collector height adjustment brackets to the front of the sweeper housing using counter sunk screws and lock nuts.

Attach the collector to the sweeper by folding the catch lever up. Slide the container down on to the two adjustable hooks and fold the catch lever down to lock in to place. (see diagram 1)

6.2 Container - Adjustment:

The height of the container may be altered by means of the black handles on the height adjustment brackets. There is a graduated indicative scale. The collector should be set evenly and level with the front edge 4cm from the surface. The adjustment is affected by the sweeping brush height and so should be monitored.

As the brush wears adjustments will need to be made.

Attention : Never allow the collector to rub the ground!!!

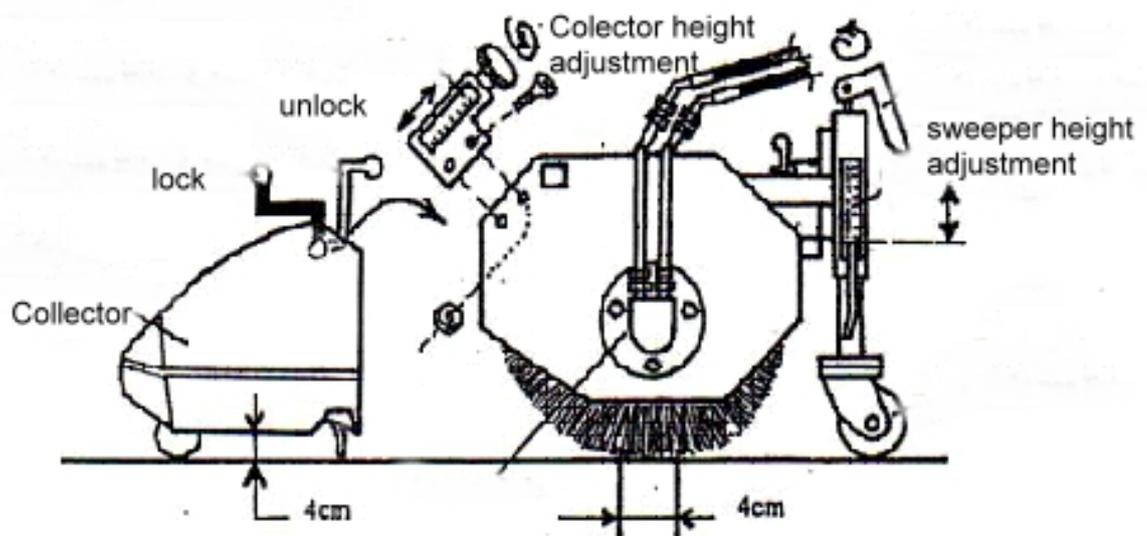

6.3 Assembly - side broom

When attaching the side brush to the sweeper housing for the first time the drive pulley and support casing needs to be fitted to the right hand of the sweeper housing as viewed from the operating position. Remove the 17mm clamping bolt, discard the flat washer. Refit the clamping bolt including the spring washer and drive pulley. Now mount the support casing using four screws, lock washers and nuts. The screws should be outside and the nuts inside. The side brush may now be slid on to the support casing and secured with the M8 screw and spring washer. "A".

Insert coach bolt "B" and assemble sweeper head assy. Using 17mm lock nut and flat washer. Do not over tighten to allow free movement of sweeper arm. Secure sweeper arm in the upright position with spring clip "C"

Position the drive belt around the drive pulley within the mounting plate. The top belt should lay with its back against the white roller at point "X" and be at the top of the drive pulley.

The belt is tensioned in to the work position by removing spring clip "C" and folding side brush arm down. Replace spring clip for safe storage. Correct tension is achieved when a distance of 5mm is measured between the tension grasp and tube (Point "Z").

The spring pivot of the gulley brush arm assembly allows lateral movement in case of obstacles.

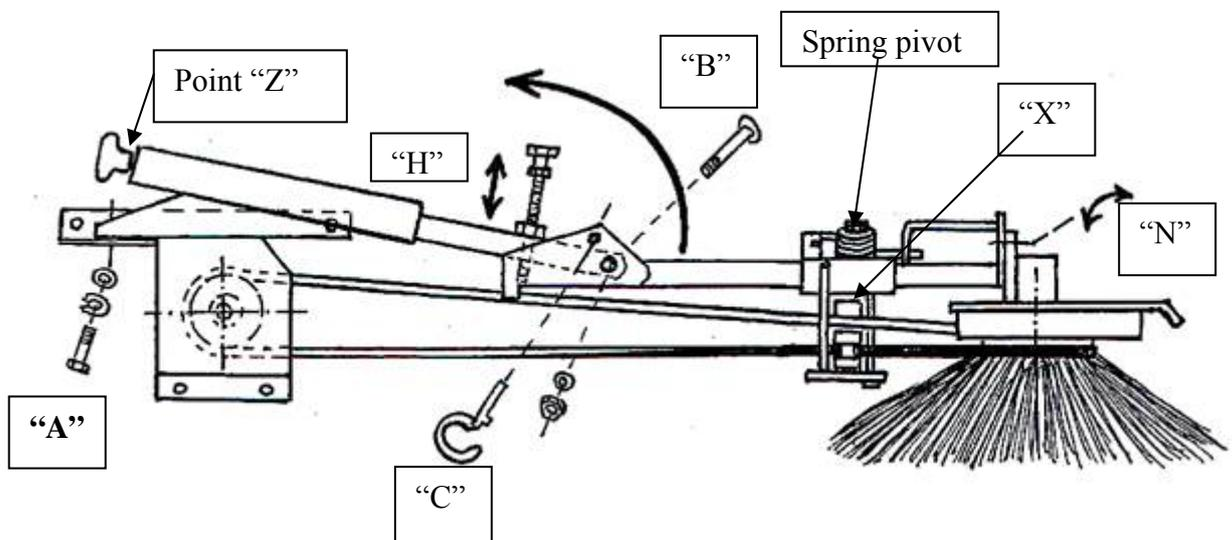

Adjustment possibilities with the side broom

"H" = height adjustment of the side broom is made by turning grasp "H". Anti-clockwise lowers the brush for more contact with the ground. Clockwise raises the brush for less contact with the ground.

Please note that adjusting the height of the main brush will affect the height setting of the gulley brush!!

"N" = Angle adjustment for gulley brush head. This may be set by loosening 13mm screw, adjusting and retightening.

"C" = Allows the brush to become inoperative by folding it out of use. Lock it in the up position using spring clip to secure it.

Easy removal of the side broom

To dismantle the assembly remove screw "A", slide assembly forwards and remove the belt laterally from the drive pulley.

Easy side broom attachment

Fit the drive belt by sliding it over the pulley. Locate the brush assembly on the mounting plate replace screw "A".

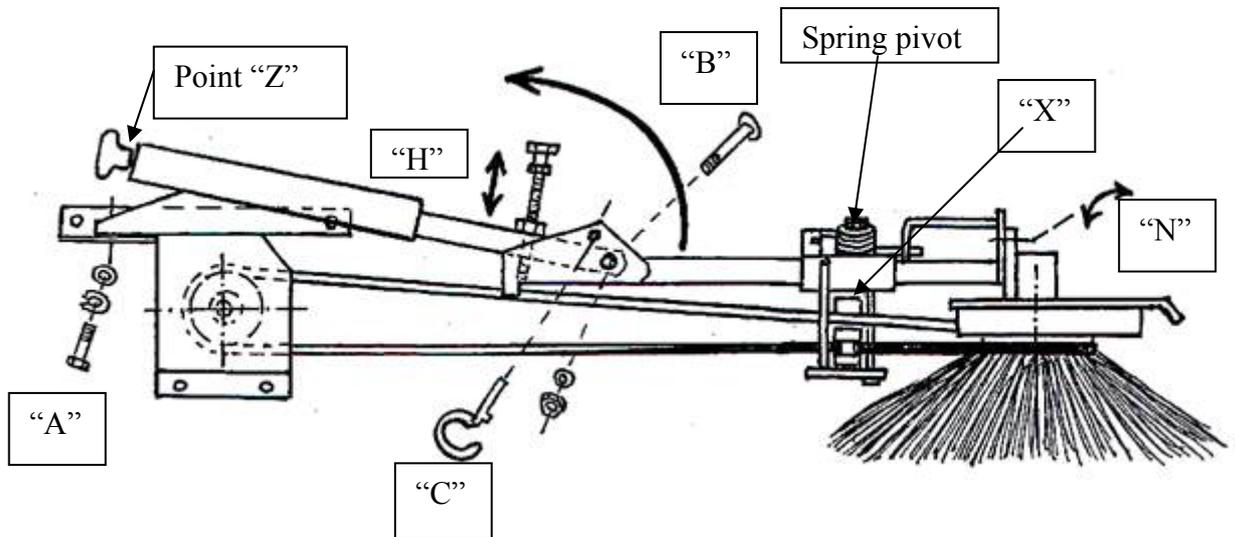

6.4 Assembly -water dust suppression unit:

When used on a sweeping machine without collector the water nozzles are mounted on the front, top edge of the sweeper housing as represented in sketch 1.

With the FKM 1050 one nozzle may be mounted centrally or when two nozzles are employed they should be mounted 500mm from each other and 250 mm from the centre.

With the FKM 1255 the two water nozzles should be mounted 625mm from each other.

The water nozzles, when used on the collector, are mounted in a similar way but on the top front edge of the collector box, 40mm up from the centre line.

For each water nozzle support plate there must two drillings each with diameter 8.5mm and 30mm from each other on the sweeping machine roof and/or the collector. Each support plate is fixed with two screws M8 x 16, lock washers and nuts.

(see sketch)

with collector:

without collector:

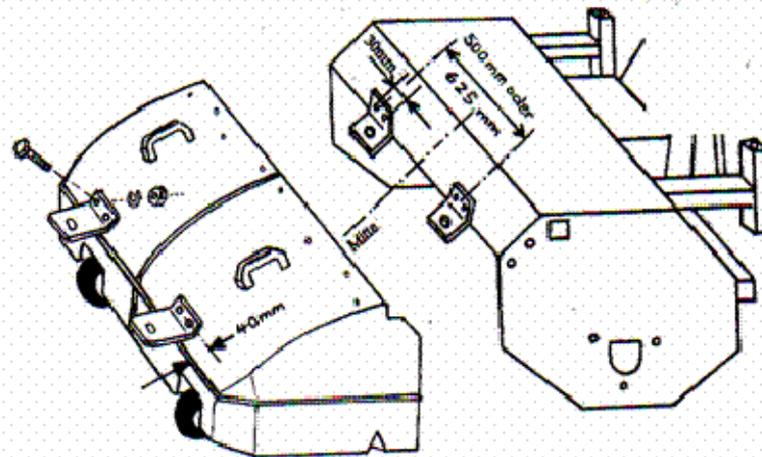

The 5 litre water tank bracket should be mounted on the right of the handle bar of the K2000

2 x 8.5mm holes must be drilled from each other and 260mm the top along the centre line of handlebar upright.

Caution – take care of oil tank.

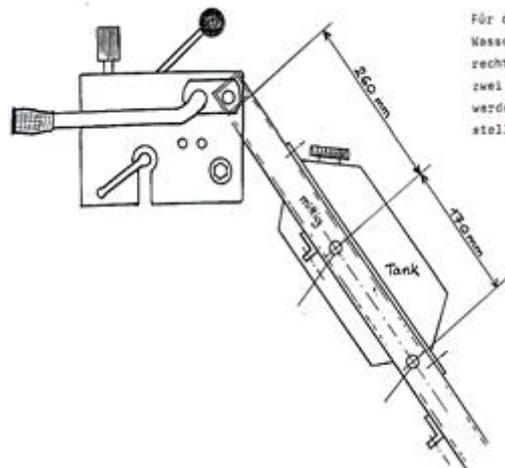

upright
170mm
from the

7. Operation

7.1 Operating instructions – power unit:

Adjusting handlebars :

Loosen the 17 mm screws in elongated slots, one each side of the control console.

Adjust the handlebars to the desired height and retighten screws.

Engine :

Please use engine manufacturers information from the enclosed operating instructions for this.

Attaching implements:

Align power unit with implement connector and slide together.

Connect hydraulic pipes by sliding back collars and inserting ends.

Ensure equipment is well greased and dirt free.

Lubricate adjusters and mounting points of the machine regularly!

Wheel drive:

The forwards/reverse lever is operated from the left hand handle bar.

Forward by tightening the left lever towards you 0 to 7 km/h

Backwards by squeezing the lower lever forwards 0 to 3.5 km/h

The fastest driving speed (forwards and reverse) can be adjusted through the left rotary control.

Implement drive :

The implement can be started or switched off by using the PTO lever on the right of the operating console.

By using the right rotary button you can adjust the number of revolutions of the brush or other implement. e.g. slowly with dust and faster with snow.

Caution. Do not engage PTO without implement attached.

7.2 Operating instructions to Sweeping machine:

Height adjusters "A" control the brush depth settings . Twisting them clockwise will lower the brush – anticlockwise will raise the brush. The base setting from which to work is when 40mm of the brush is in contact with the surface to be swept. Always adjust the brush evenly to achieve even wear. The graduation scale on the side of the adjusters provides an indication of setting. (see sketch 1)

Sketch 1

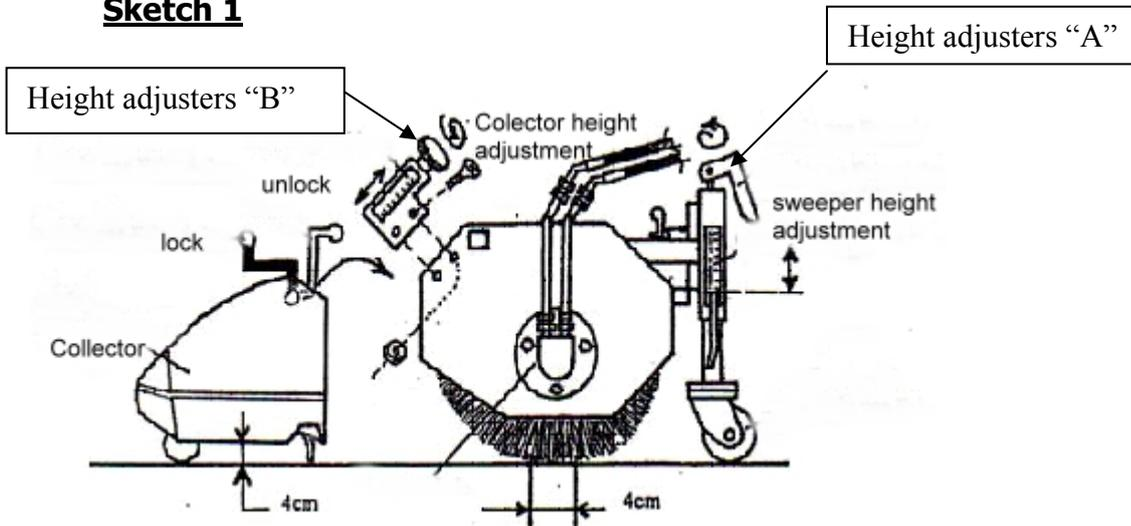

7.3 Collector - adjustment: (see sketch 1)

Height adjusters "B" control the box level settings. Twisting them clockwise will raise the box – anticlockwise will lower the box. The base setting from which to work is when box is level to the ground ie there is a parallel gap of 40mm between the surface to be swept and the bottom of the box. The graduation scale on the side of the adjusters provides an indication of setting.

Note: Sweeping machine collector must never rub the ground!!!

7.4 Side broom - adjustment:

See assembly – Side broom **3.3**

8. Maintenance

8.1 General information



Note!

Injuries to people or Damages to the machine can occur. You should check before each use that the machine is safe and the relevant parts and hydraulic connections are properly connected.

8.2 Maintenance

- The sweeping machine must be submitted to regular maintenance.
- After use you must dismantle all the safety devices for reattachment when the machine is used again.
- check all fixings and pin connections after the first 5 hours of use and lubricate all mobile parts
- check the tightness of the hydraulic fittings before every use.
- check hydraulic fittings after 5 hours use for the first time, and tighten if necessary

(Important note: Only tighten joint if it is leaking. Procedure: Loosen the screw connection then move hose left and right. Now the screw connection can be tightened again.

8.3 Daily maintenance

- check the safety and control parts for wear before every use.
- check the oil level and Air filter.
- check the Hydraulic fittings and linings
- check the air pressure in the wheels.
- do a test run before every use.
- clean the equipment after every use.
- regularly lubricate all adjustable and moving parts on the power unit and any attachments.

Storage settings

- Sweeping brush: adjust wheels so that the brush is off the floor making sure the sweeping brush is evenly relieved
- Side brush: only store off the ground.

8.4 **Maintenance after 20 and 100 hours use or longer**

All mobile parts must be greased and oiled regularly including at the beginning and the end of each season.

Oil change Honda motor:

Change For the first time after 20 hours use, then every 100 hours use after that for further information, see engine manual.

Hydraulic oil change:

The hydraulic oil and oil filter should be changed after the first 20 hours and then after every 100 hours

Type of oil used: BP Biohyd SE-S46 (biologically degradable Ester based) or similar.

Check chain tension between hydraulic motor and differential.

8.5 Installing a replacement sweeping brush

Remove the 17mm long clamping bolt from the sweeping machine housing
Loosen the three screws on the bearing housing and remove clamp and bearing assembly. Take the square drive tube out of the two sectioned sweeping brush and remove brushes.

Install new brush - so that the round 145mm recess is on the right as shown and fits over the hydraulic motor - see sketch. Then reinstall the drive tube in reverse with the clamp and the square bar, and install the left hand bearing and clamp.

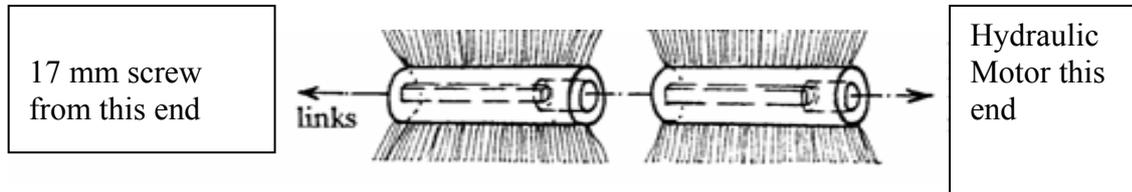

9 **Technical Data:**

Power Unit:

Engine: Honda four-cycle petrol engine 6,6kW (9PS)
Regular grade fuel, lead free
Option of electric start model as above = K 2000/E

Transmission:

Hydrostatic with differential axle
Infinitely variable speed adjustment
Adjustable handlebar
Hydraulic drive for attachments with infinitely variable speed
Equipment quick attach system
Forward 0 to 7 km/h (infinitely variably)
Backwards 0 to 3.5 km/h
Standard tyre = 4.00-8 block profile
Tyre options = 4.00-8 lug tread
or 16x6,50 -8 block or lug tread
Option: Side light and headlight
tyre chains wheel weights
Noise emission: 83 dba

8.2 Sweeping machine:

Hydrostatic drive, work width 100 or 125cm
Brush diameters 370mm or 450 mm
Hydraulic drive for sweeper with infinitely variable speed
Standard brush is 5 row poly combination brush.
Brush options: Full poly brush, full poly/steel brush,
4 row poly snow brush .

Conformity explanation

Conformity explanation of the manufacturer (article 8 that Guideline 98/37/EG)

We,

Kersten Maschinen – Vertriebs GmbH

Empeler road 93-95

D - 46459 Rees

explain that the machine

Hand-guided front sweeping machine with combustion engine

Fabrikmarke: **Kersten**

Typ: **K 2000 / K 2000/E**

mit folgenden EG-Richtlinien übereinstimmt:
98/37/EG,



Rees, den 26.04.04

Dipl.-Ing. Georg

Kersten

Geschäftsführer-

1 Parts List K 2000 :

Drives

Nr.	Part Nr.	Qty.	Description
1	700 200 010	1	Housing K 2000
2	922 001 001	1	Differential Axle
3	920 501 045	1	Chain Sprocket
4	900 008 016	4	Nut
5	920 101 056	1	Chain
6	908 047 440	2	Parallel key
7	905 800 100	1	Circlip
8	924 200 205	4	Bearing Plate
9	924 100 205	2	Bearing
10	700 000 021	2	Bush
11	700 000 022	2	Wheel hub f.R.4.00-8
12	700 000 023	2	Wheel hub f.R.16x6,50-8
13	901 008 016	6	Bolt
14	905 008 000	6	Lock washer
15	900 008 001	6	Nut
16	700 000 170	1	Locking pin
17	909 100 189	1	Spring
18	700 000 171	1	Locking pin plug
19	700 000 172	1	Lever
20	901 005 020	1	Bolt
21	900 005 002	1	Locknut

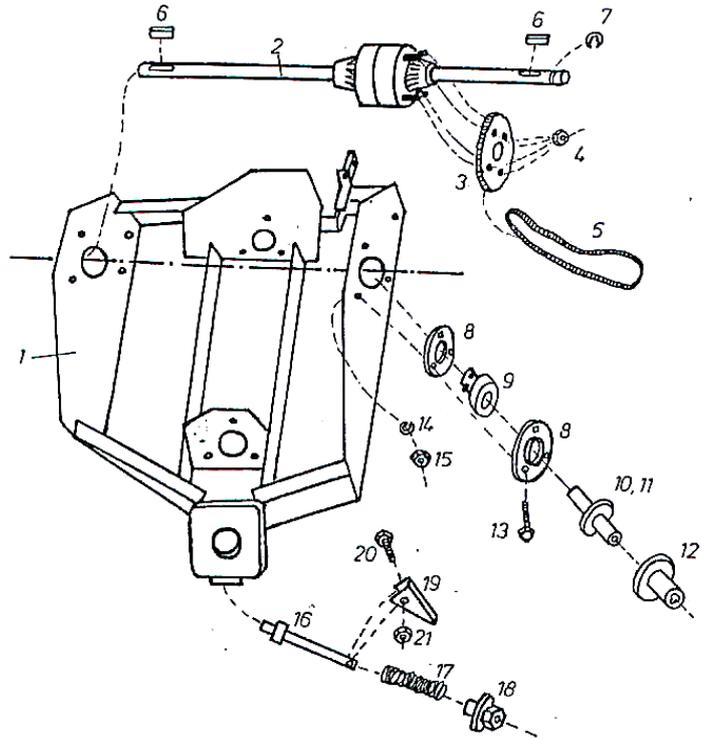

Wheels

Nr.	Part Nr.	Qty.	Description
1	700 000 050	1	Hydraulic hose housing
2	901 008 016	6	Bolt
3	905 008 000	6	Lock washer
4	900 008 001	6	Nut
5	700 000 055	2	Fender
6a	926 140 408	2	Block tyre 4.00-8
6b	926 110 408	2	Cleated tyre 4.00-8
6c	926 140 168	2	Block tyre. 16x6,50-8
6d	926 110 168	2	Cleated tyre 16x6,50-8
7	901 012 025	8	Bolt
8	907 012 000	8	Washer
9	900 012 001	8	Nut
10	943 300 035	2	Hub cover
			Options:
10	945 104 008	2	Wheel weights for 4.00-8
10	945 101 665	2	Wheel weights for 16x6,50-8
10	901 012 060	4	Bolt
10	905 012 000	4	Lock washer
10	905 112 000	4	washer
10	902 912 040	4	Threaded sleeve

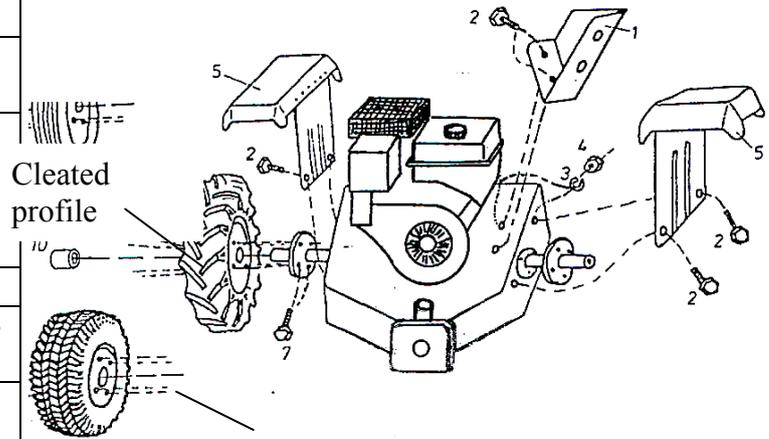

Block profile
6 a, c

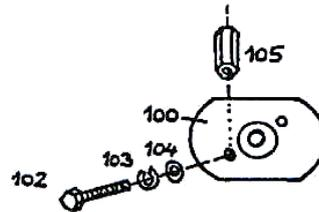

2 Hydraulic Drive

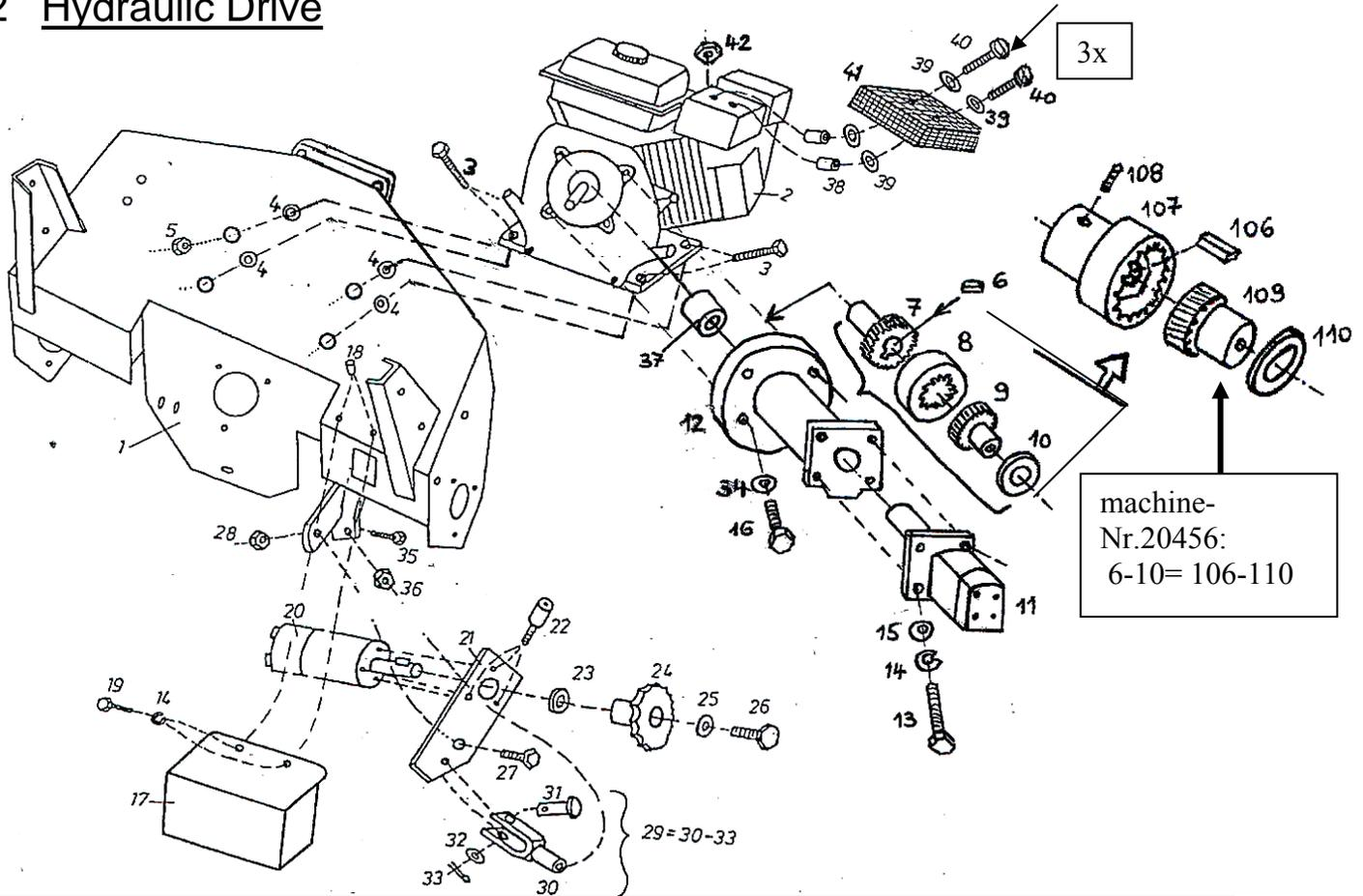

Nr.	Part-Nr.	Qty.	Description	Nr.	Part-Nr.	Qty.	Description
1	700 200 010	1	Main housing K 2000	25	905 106 000	1	Washer
2a	920 000 002	1	Honda-Engine 9PS	26	901 006 012	1	Bolt
2b	920 000 004	1	Honda-Eng. 9PS+E-St	27	901 012 030	1	Bolt
3	901 008 040	5	Bolt	28	900 012 001	1	Nut
4	905 008 000	8	Lockwasher	29	908 408 032	1	Adjuster linkage complete
5	900 008 001	5	Nut	30		1	Adjuster linkage fork
6	908 007 725	1	Parallel key	31	908 508 020	1	Pin
7	925 101 200	1	Clutch-Engine side	32	905 108 000	1	Washer
8	925 102 200	1	Clutch coupling sleeve	33	907 216 016	1	Split pin
9	925 103 200	1	Clutch-Pump side	34	905 008 000	4	Lockwasher
10	925 104 200	1	Clutch disc-Scheibe	35	901 008 040	1	Bolt
11	934 110 037	1	Hydraulic pump	36	900 008 001	1	Nut
12	700 001 251	1	Pump housing	37	705 350 520	1	Spacer 20mm
13	902 206 030	4	Bolt	38	705 121 515	3	Spacer
14	905 006 000	6	Lockwasher	39	905 205 000	6	K-washer
15	905 106 000	4	Washer	40	901 105 030	3	Bolt
16	901 008 030	4	ScrewM8x25-30	41	700 000 047	1	Grill
17	700 100 036	1	Hydra-Motor cover	42	900 005 002	1	Locknut
18	900 006 004	2	Nut				
19	901 006 012	2	Bolt	Nr. 106-110 = ab	Mach. Nr. 20456 replaces 6-10 :		
20	935 101 040	1	Hydraulic motor OMP40	107	+109 =		- see also page14 ! -
21	700 000 035	1	Motor-mounting		925 100 028	1	Cluch hub 2-piece
22	901 806 020	3	Bolt	106	908 007 733	1	Parallel key (v.Honda-Motor)
23	701 301 503	1	Disc	108	902 306 008	1	Grubscrew
24	920 401 010	1	10 toothed cogg	110	925 104 028	1	Pump disk
24 a	920 401 012	1	12 toothed cogg		999 925 001	106bis	110= Complete conversion kit

Optional Hatz-Diesel Engine 4,6 kW

Also available with E-Start

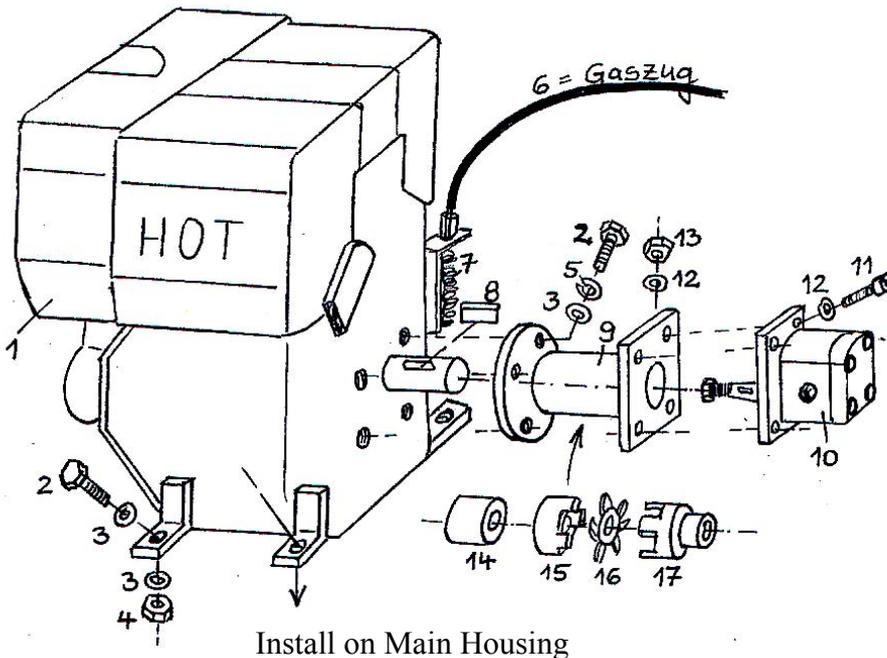

Nr.	Part-Nr.	Qty.	Description
1a	920 300 046	1	Hatz-Diesel engine 4,6kW 1 B 30
1b	920 301 046	1	Hatz-Diesel engine 4,6kW mit Electric-Start
2	901 008 025	8	Bolt
3	905 108 000	12	Washer
4	900 008 002	4	Locknut
5	905 008 000	4	Lockwasher
6a	940 200 970	1	Außenzug Gas-Aggregat (wie bei Benzin-Motor)
6i	940 200 970	1	Innenzug Gas-Aggregat (wie bei Benzin-Motor)
7		1	Spring u.a. Parts - see parts catalog of the Hatz engine!
8	908 00	1	Parallel key
9	700 132 251	1	Pump mounting
10	934 100 037	1	Hydraulic pump D 3,7
11	902 206 030	4	Bolt
12	905 106 000	8	Washer
13	900 006 002	4	Lockwasher
14	705	1	Bush
15	925 101 132	1	Clutch Engine side with drilling
16	925 102 064	1	Clutch Coupler
17	925 103 019	1	Clutch pump side
			Stand 06 / 2002

Steering Column

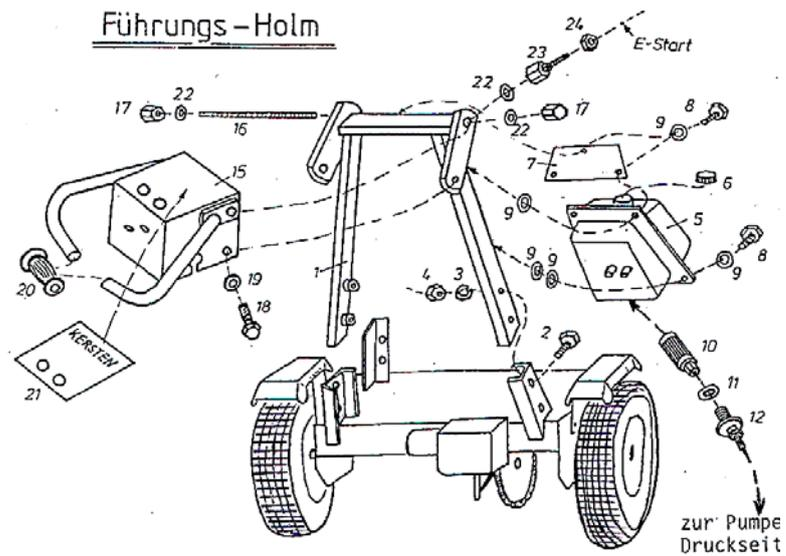

Nr.	Part-Nr.	Qty.	Description	Nr.	Part-Nr.	Qty.	Description
1	700 000 065	1	Steering column	15	700 200 090	1	Switch housing
2	901 008 040	4	Bolt	16	700 000 082	1	Threaded rod
3	905 008 000	4	Lockwasher	17	900 012 003	2	Nut
4	900 008 001	4	Nut	18	901 010 020	2	Bolt
5	700 000 070	1	Tank	19	905 210 303	2	Washer
6	931 200 042	1	Screwcap	20	941 110 700	2	Handgrip
7	700 000 073	1	Tank-coverplate	21	700 200 094	1	Adhesive label
8	901 006 012	5	Bolt	22	905 112 000	2	Washer
9	905 106 000	11	Washer	bei E-Start replaces 1x nut Nr.17			
10	937 200 010	1	Filter element	23	700 000 310	1	Fixing bolt
11	937 105 830	1	Washer	24	900 006 001	1	Nut
12	700 000 074	1	Filter holder				

3 Electric-Start

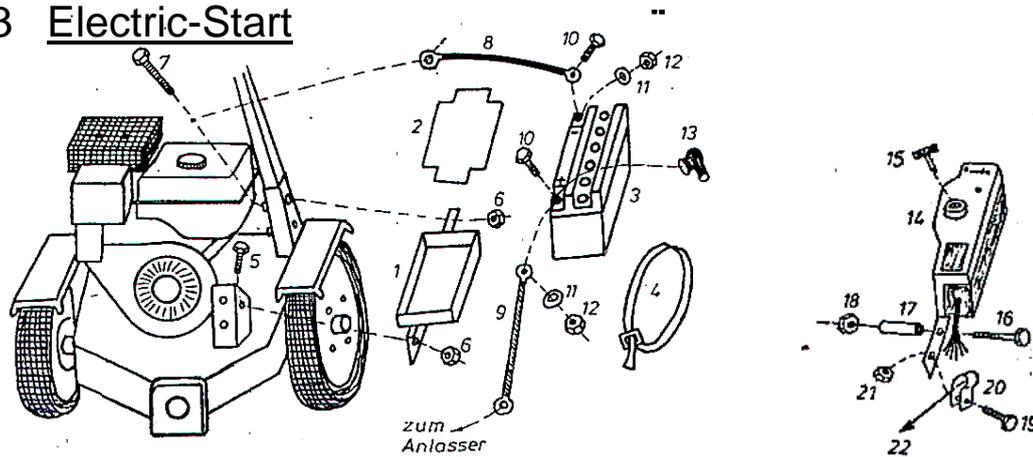

Nr.	Part-Nr.	Qty.	Description	Nr.	Part-Nr.	Qty.	Description
1	700 000 301	1	Battery box	12	900 006 001	2	Nut
2	700 000 305	1	Battery mat	13	960 041 000	2	Terminal cap
3	960 011 218	1	Battery	14	960 000 001	1	Electric-Start-Block
4	960 031 000	1	Battery fixing band	15	960 000 101	1	Key for E-Start
5	901 008 020	1	Bolt	16	901 106 070	1	Bolt
6	900 008 001	2	Nut	17	705 121 560	1	Spreader tube
7	901 108 050	1	Schr-statt 901108 040	18	900 006 001	1	Nut
8	960 021 308	1	Battery cable (negative)	19	901 006 012	1	Bolt
9	960 022 308	1	Battery cable (positive)	20	908 612 015	1	Cable clamp
10	901 006 016	2	Bolt	21	900 006 002	1	Lock nut
11	905 106 000	2	Washer	22	700 000 211	1	E-Start cables

Hydraulic lines and circuit

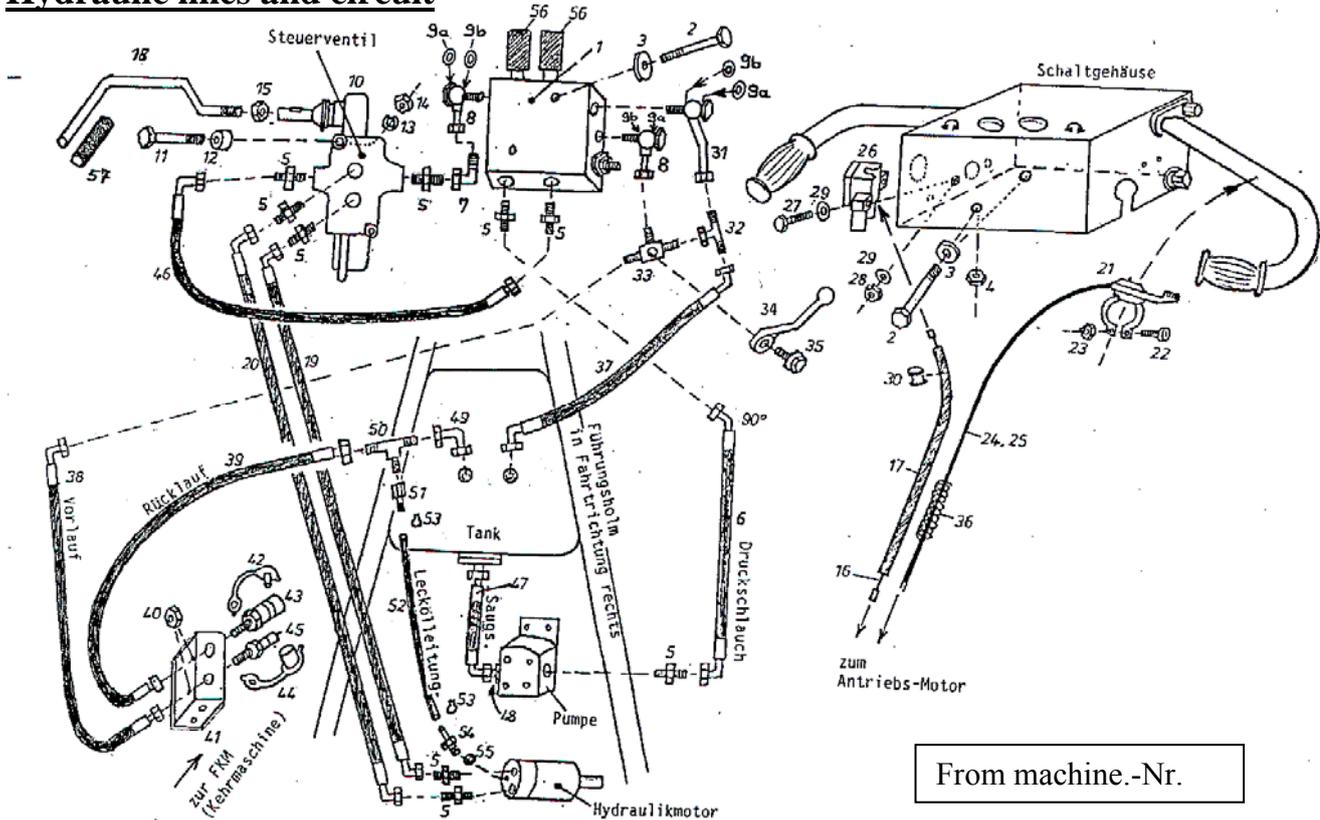

From machine.-Nr.

Nr.	Part-Nr.	Qty.	Description	3.1.1.	Part-Nr.	Qty.	Description
1	936 202 000	1	Regulating valve, comp.	29	905 104 000	2	Washer
2	901 106 050	2	Bolt	30	908 706 646	1	Cable sleeve
3	905 206 251	2	Washer	31	931 260 001	1	Steel connecting pipe.
4	900 006 001	2	Nut	32	931 051 200	1	Hydr screw connector
5	931 071 238	9	Hydr screw connector	33	931 141 218	1	3-way connector 33-35
6	930 000 022	1	Hydraulic hose	34	931 150 900	1	Lever
7	931 061 200	1	Hydr screw connector	35	903 305 008	1	Ratchet screw
8	931 260 002	2	Steel connector, straight	36	909 100 166	1	Spring
9a	937 100 038	3	Copper washer	37	930 000 043	1	Hydraulic hose
9b	937 101 038	3	O ring	38	930 000 030	1	Hydraulic hose
10	936 131 000	1	Control valve	39	930 000 015	1	Hydraulic hose
11	901 108 065	2	Bolt	40	900 018 010	2	Nut
12	705 200 509	2	Bush	41	700 000 050	1	Hydr hose mounting
13	905 008 000	2	Lockwasher	42	932 391 022	1	Hydr protection cap
14	900 008 001	2	Nut	43	932 261 223	1	Hydraulic sleeve
15	900 010 001	1	Nut	44	932 391 032	1	Hydr protection cap
16	700 110 000	1	Cable, 1-adrig 1100mm	45	932 161 323	1	Hydraulic plug
17	700 102 000	1	Sleeve 1020mm	46	930 000 001	1	Hydraulic hose
18	700 201 110	1	Shift lever	47	930 000 006	1	Hydraulic hose
19	930 000 041	1	Hydraulic hose	48	931 071 538	1	Hydr screw connector
20	930 000 042	1	Hydraulic hose	49	931 251 290	1	Elbow screw connector
21	941 130 020	1	Throttle=21-23	50	931 191 206	1	Hydr screw connector
22	901 705 020	1	Bolt	51	931 262 604	1	Nut with Nippel
23	900 005 001	1	Nut	52	930 900 580	1	Oil hose 580 mm
24	940 101 105	1	Throttle cable inner	53	908 300 123	2	Hose clip
25	940 200 970	1	Throttle cable outer	54	931 260 154	1	Connector
24+25	700 001 204	1	Throttle cable complete	55	937 110 201	1	O ring
26	941 120 110	1	Stop switch	56	941 230 328	2	Regulator knob
27	901 004 020	2	Bolt	57	700 000 111	1	Heatshrink sleeve
28	900 004 002	2	Locknut	57...	700 006 110	1	Lever complete+15+18

Hydraulic angling

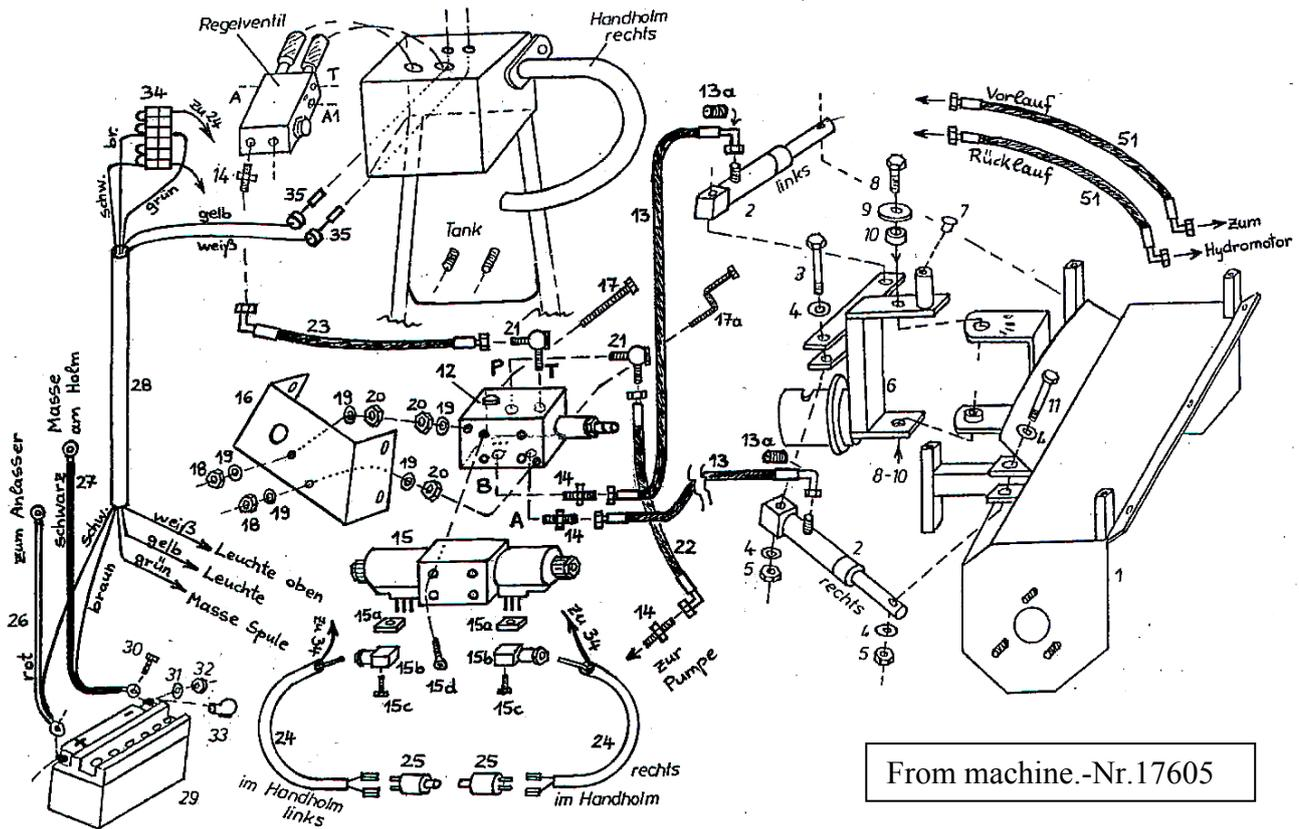

From machine.-Nr.17605

Nr.	Part-Nr.	Qty.	Description	3.1.1.	Part-Nr.	Qty.	Description
1		1	Housing + 2 Hydr rams.	18	900 006 002	2	Locknut
2	933 307 057	2	Hydraulic ram	19	905 106 000	5	Washer
2a	937 407 057	2	Gasket kit	20	900 006 001	3	Nut
3	901 110 070	2	Bolt	21	931 111 238	2	Hydr screw connector
4	905 110 000	8	Washer	22	930 000 046	1	Hydraulic hose
5	900 010 002	4	Locknut	23	930 000 002	1	Hydraulic hose
6	700 902 266	1	Coupling with ram brackets	24	700 902 270	2	Switching cable
7	937 418 000	1	Plug	25	941 900 301	2	Pushbutton switch
8	901 010 025	2	Bolt	26	700 902 371	1	Battery cable negative
9	905 210 303	2	Washer	27	700 902 372	1	Battery cable positive
10	705 205 135	2	Bush 13,5mm	28	700 902 375	1	Cable harness
11	901 110 060	2	Bolt	29	960 011 218	1	Battery
12	936 206 000	1	Base plate	30	901 006 016	2	Bolt
13	930 000 053	2	Hydraulic-hose	31	905 106 000	2	Washer
13a	700 902 269	2	Choke jet	32	900 006 001	2	Nut
14	931 071 238	4	Hydr screw connector	33	960 041 000	2	Terminal cap
15	936 306 012	1	Elektric valve	34	912 703 000	1	Connectorl block
15a	936 101 080	2	Rubber sealing cap	35	941 900 001	2	Light switch
15b	936 102 080	2	Top cap				
15c	936 103 080	2	Bolt M3x30	51	930 001 004	2	Hydraulic hose
15d	901 995 045	1	Set of bolts (4)				replaces 2x51 Page 17
16	702 000 230	1	Cover				Exchange with
17	901 006 120	1	Bolt				hydraul. Angling!
17a	901 006 999	1	Bolt 2x curved				

4 Attachment : Sweeping Machine with 370mm diameter brush

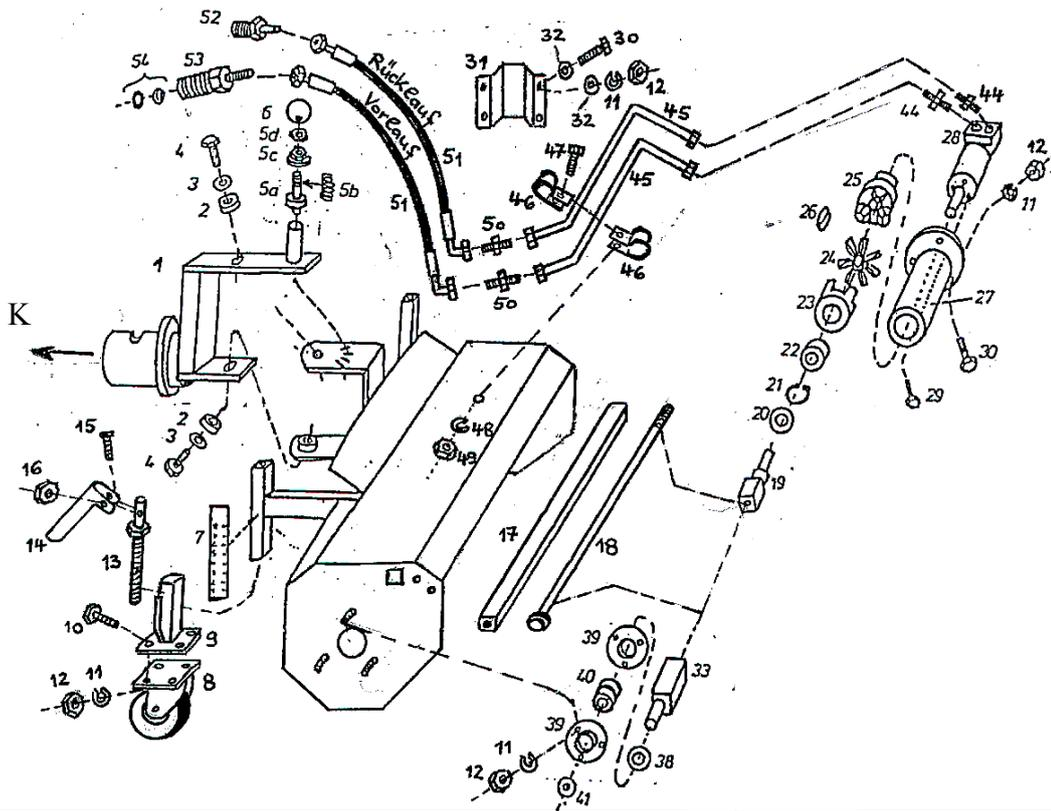

Nr.	Part-Nr.	Qty.	Description	Nr.	Part-Nr.	Qty.	Description
1	700 002 266	1	Coupling K2000	26	908 005 516	1	Parallel key
2	705 205 135	2	Bush 13,5mm	27	110 000 040	1	Drive housing
3	905 210 303	2	Washer	28a	935 111 032	1	Hydr. motor FKM1050
4	901 010 025	2	Bolt	28b	935 111 050	1	Hydr. motor FKM1255
5a	700 001 170	1	Stop	29	901 806 020	3	Bolt
5b	909 100 189	1	Spring	30	901 008 020	3	Bolt
5c	700 000 171	1	Plug	31	110 370 051	1	Special shield for flow lines
5d	900 010 001	1	Nut				
6	941 220 010	1	Knob	32	905 108 000	8	washer
7	700 000 151	2	Height scale	33	100 000 430	1	Drive stub, right
8	926 302 140	2	Caster				
9	100 000 485	2	Caster mounting	38	905 125 000	3	Washer
10	901 008 016	8	Bolt	39	924 200 205	2	Disc
11	905 008 000	14	Lockwasher	40	924 100 205	1	Bush
12	900 008 001	14	Nut	41	905 210 303	1	Washer
13	100 000 490	2	Spindle	44	931 071 238	2	Hydr. screw connector
14	700 000 085	2	Handle	45	110 370 050	2	Hydraulic pipe
15	901 005 020	2	Bolt	46	908 612 015	2	Pipe clamp
16	900 005 002	2	Locknut	47	901 006 016	1	Bolt
17.1	100 000 440	1	Drive shaft for 1,0m	48	905 006 000	1	Lockwasher
17.2	125 000 440	1	Drive shaft for 1,25m	49	900 006 001	1	Nut
18.1	100 000 435	1	Connecting rod 1,0m	50	931 091 200	2	Hydr. screw connector
18.2	125 000 435	1	Connecting rod 1,25m	51	930 000 015	2	Hydraulic hose
19	110 000 425	1	Drive stub, left	52	932 131 323	1	Hydraulic plug conn.
20	110 000 010	1	Washer	53	932 231 223	1	Hydraulic sleeve conn.
21	906 000 470	1	Circlip	54	937 300 028	1	Gasket kit for sleeve conn
22	924 106 005	1	Bush				
23	925 203 016	1	Clutch front				
24	925 202 098	1	Clutch driver				
25	925 201 016	1	Clutch- Motor side				
23-25	925 002 000	1	Clutch, complete				

5 Attachment : Sweeping Machine with 450 mm diameter brush

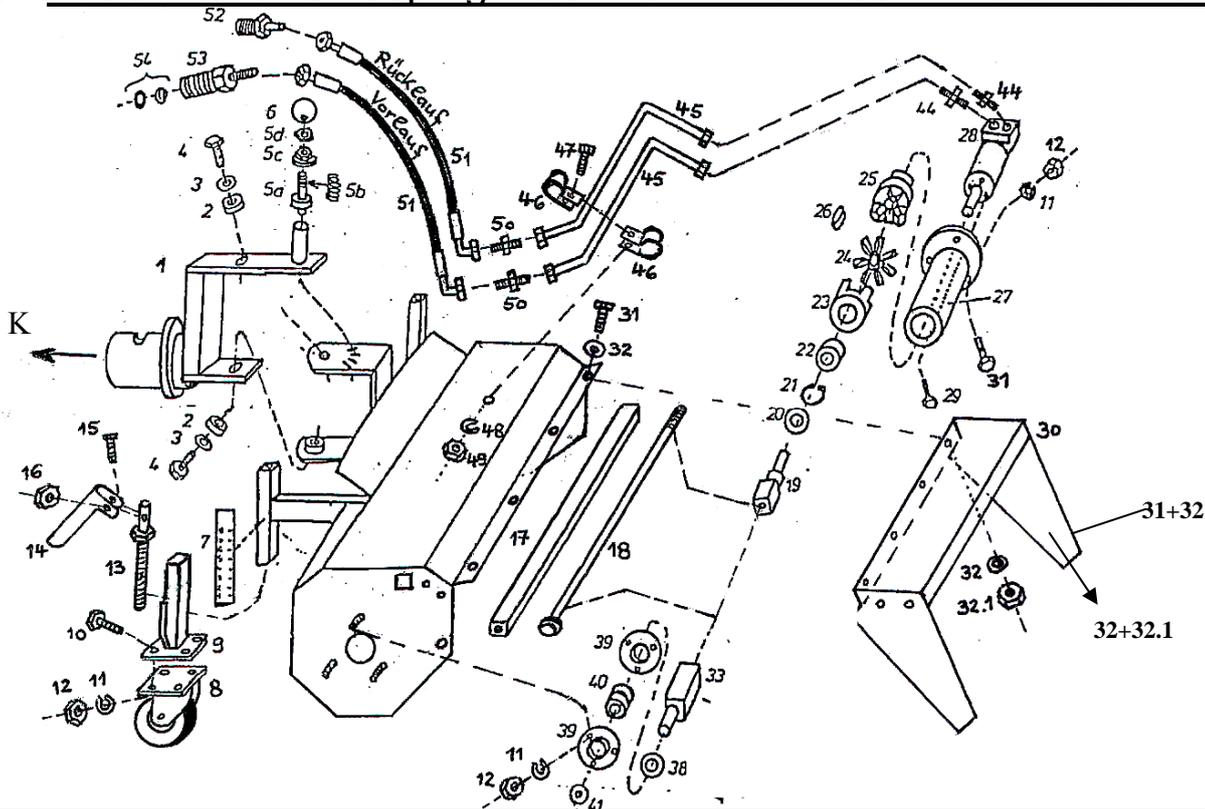

Nr.	Part-Nr.	Qty.	Description	Nr.	Part-Nr.	Qty.	Description
1	700 002 266	1	Coupling K2000	26	908 005 516	1	Parallel key
2	705 205 135	2	Bush 13,5mm	27	110 000 040	1	Drive housing
3	905 210 303	2	Washer	28	935 111 050	1	Hydraulic motor
4	901 010 025	2	Bolt	29	901 806 020	3	Bolt
5a	700 001 170	1	Stop	30a	100 450 700	1	Cover 1,00 m
5b	909 100 189	1	Spring	30b	125 450 700	1	Cover 1,25 m
5c	700 000 171	1	Plug	31	901 008 020	9/11	Bolt (1,0 / 1,25m)
5d	900 010 001	1	Nut	32	905 108 000	12/16	Washer
6	941 220 010	1	Knob	32.1	900 008 002	6/8	Locknut (1,0/1,25m)
7	700 000 151	2	Height scale				
8	926 302 140	2	Caster	33	100 000 430	1	Drive stub, right
9	100 450 485	2	Caster mounting				
10	901 008 016	8	Bolt	38	905 125 000	3	Washer
11	905 008 000	14	Lockwasher	39	924 200 205	2	Disc
12	900 008 001	14	Nut	40	924 100 205	1	Bush
13	100 000 490	2	Spindle	41	905 210 303	1	Washer
14	700 000 085	2	Handle	44	931 071 238	2	Hydr. screw connector
15	901 005 020	2	Bolt	45	110 450 050	2	Hydraulic pipe
16	900 005 002	2	Locknut	46	908 612 015	2	Pipe clamp
17.1	100 000 440	1	Drive shaft for 1,0m	47	901 006 016	1	Bolt
17.2	125 000 440	1	Drive shaft for 1,25m	48	905 006 000	1	Lockwasher
18.1	100 000 435	1	Connecting rod 1,0m	49	900 006 001	1	Nut
18.2	125 000 435	1	Connecting rod 1,25m	50	931 091 200	2	Hydr. screw connector
19	110 000 425	1	Drive stub, left	51	930 000 015	2	Hydraulic hose
20	110 000 010	1	Washer	52	932 131 323	1	Hydraulic plug conn.
21	906 000 470	1	Circlip	53	932 231 223	1	Hydraulic sleeve conn.
22	924 106 005	1	Bush	54	937 300 028	1	Gasket kit for sleeve conn
23	925 203 016	1	Clutch front				
24	925 202 098	1	Clutch driver				
25	925 201 016	1	Clutch- motor side				
23-25	925 002 000	1	Clutch complete				

Sweeping Machine-Accessories (Plastic-Collector Box from 04/2001!)

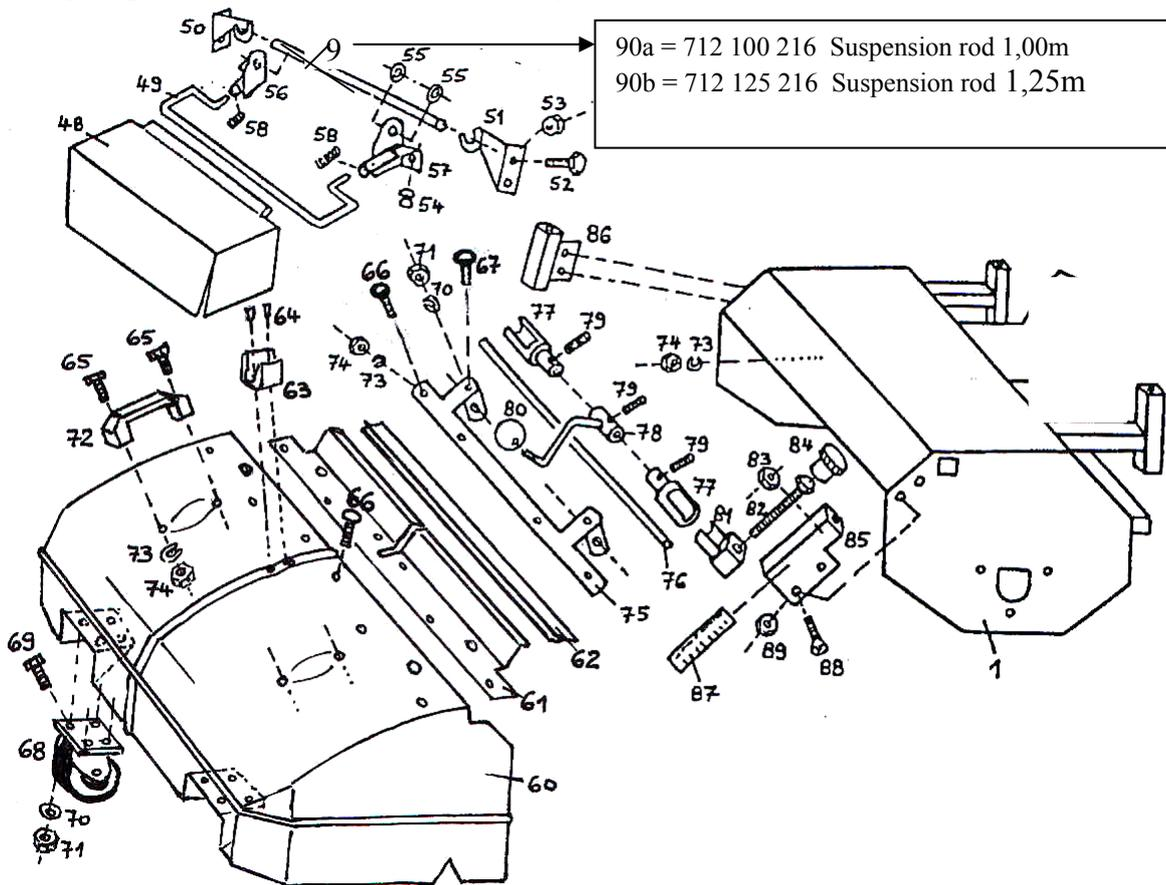

Nr.	Part-Nr.	Qty	Description	Nr.	Part-Nr.	Qty.	Description
48a	712 100 094	1	Spray guard 1,00m	68	926 301 076	2	Caster
48b	712 125 094	1	Spray guard 1,25m	69	901 008 016	8	Bolt
49a	712 100 095	1	Stretcher bar 1,00m	70	905 008 000	10	Lockwasher
49b	712 125 095	1	Stretcher bar 1,25m	71	900 008 001	10	Nut
50	712 000 096	1	Support plate right	72	941 636 006	2	Handlef
51	712 000 097	1	Support plate left	73	905 006 000	10	Lockwasher
52	901 008 016	4	Bolt	74	900 006 001	10	Nut
53	900 008 002	4	Locknut	75a	712 100 115	1	Catch rail 1,00m
54	943 700 910	2	Buffer	75b	712 125 115	1	Catch rail 1,25m
55	906 510 000	4	Lock washer	76a	712 100 116	1	Catch bar 1,00m
56	712 000 128	1	Connecting plate right	76b	712 125 116	1	Catch bar 1,25m
57	712 000 129	1	Connecting plate left	77	712 000 117	2	Container catch pipe
58	909 100 207	2	Spring	78	712 000 118	1	Container catch lever
57	712 000 129	1	Connecting plate left	79	902 306 005	3	Lock screw
58	909 100 207	2	Spring	80	941 220 008	1	Knob
60a	100 101 625	1	Plastic box 1,0m	81	712 000 120	2	Catch block
60b	125 101 625	1	Plastic box 1,25m	82	901 012 130	2	Bolt
61a	100 101 626	1	Support rail 1,00m	83	900 012 002	2	Locknut
61b	125 101 626	1	Support rail 1,25m	84	941 410 031	2	Turning knob
62a	712 100 111	1	Rubber strip 1,00m	85a	712 370 121	1	Guide rail, left- W370
62b	712 125 111	1	Rubber strip 1,25m	85b	712 450 121	1	Guide rail, left- W450
63	912 900 101	1	Lever clip	86a	712 370 122	1	Guide rail, right- 370
64	908 903 000	2	Rivets 3mm	86b	712 450 122	1	Guide rail, right- 450
65	901 006 020	4	Bolts	87	700 000 151	2	Height scale
66	901 906 020	6	Screw	88	901 208 016	4	Countersunk bolt
67	901 908 025	2	Screw	89	900 008 002	4	Lock nut

FKM 1050 and FKM 1255 : Brushes

- a) Brush - 37 cm diameter
- b) Brush - 45 cm diameter

<u>Part</u>	<u>Description</u>	<u>Part-Nr.</u>
-------------	--------------------	-----------------

Dirt Brush-Poly

ith full Poly-trimming

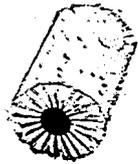

- | | | |
|-----------------|-----------|----------------|
| a) For FKM 1050 | in 100 cm | 1005 160 / 370 |
| a) For FKM 1255 | in 125 cm | 1255 160 / 370 |
| b) For FKM 1050 | in 100 cm | 1005 160 / 450 |
| b) For FKM 1255 | in 125 cm | 1255 160 / 450 |

Dirt Brush – Mixed

With approx 50% Poly/Wire trimming



- | | | |
|-----------------|-----------|----------------|
| a) For FKM 1050 | in 100 cm | 1005 165 / 370 |
| a) For FKM 1255 | in 125 cm | 1255 165 / 370 |
| b) For FKM 1050 | in 100 cm | 1005 165 / 450 |
| b) For FKM 1255 | in 125 cm | 1255 165 / 450 |

Combination Brush

ith 5-row Polly-trimming



- | | | |
|-----------------|-----------|----------------|
| a) For FKM 1050 | in 100 cm | 1005 100 / 370 |
| a) For FKM 1255 | in 125 cm | 1255 100 / 370 |
| b) For FKM 1050 | in 100 cm | 1005 100 / 450 |
| b) For FKM 1255 | in 125 cm | 1255 100 / 450 |

Snow Brush

With 4-row Poly-trimming

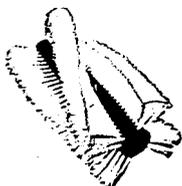

- | | | |
|-----------------|-----------|----------------|
| a) For FKM 1050 | in 100 cm | 1005 080 / 370 |
| a) For FKM 1255 | in 125 cm | 1255 080 / 370 |
| b) For FKM 1050 | in 100 cm | 1005 080 / 450 |
| b) For FKM 1255 | in 125 cm | 1255 080 / 450 |

Spare parts-list Side-Brush from 07/01,

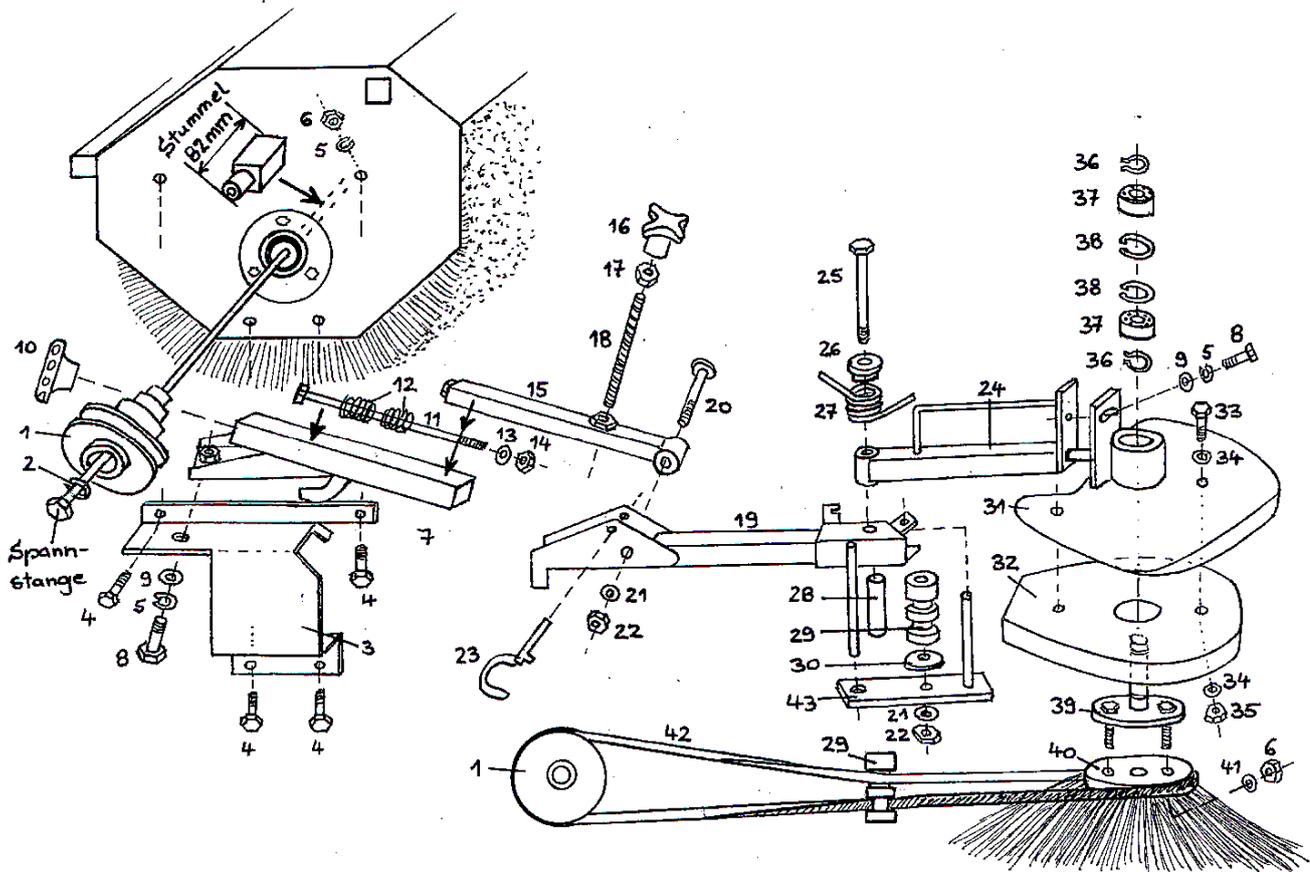

Nr.	Bestell-Nr.	Anz.	Bezeichnung	Nr.	Bestell-Nr.	Anz	Bezeichnung
1	105 000 120	1	Driving pulley	23	907 155 000	1	Quick lock pin
2	905 010 000	1	Lockwasher	24	105 000 126	1	Side broom arm part of 4
3	105 000 121	1	Mounting plate	25	901 110 150	1	screw
4	903 608 020	4	Linienkopf-Schlitz-Schr.	26	105 000 127	1	Centering bush
5	905 008 000	6	Lockwasher	27	909 300 461	1	Torsion bar
6	900 008 001	6	Nut	28	705 141 168	1	Pipe D14/11, 68lg
7	105 000 122	1	Brush side arm part 1	29	105 000 128	1	Drive belt guide roller
8	901 008 020	2	Bolt	30	905 210 000	1	K-disk
9	905 108 000	2	Washer	31	105 000 129	1	Starting protection
10	941 410 031	1	Knob	32	105 000 130	1	Side broom protection
11	901 112 130	1	Bolt	33	901 006 016	2	screw
12	909 103 288	2	Spring	34	905 106 000	4	Wearing part
13	905 112 000	1	Washer	35	900 006 002	2	Stop nut
14	900 012 002	1	Locknut	36	905 915 000	2	Circlip
15	105 000 123	1	Brush sde arm part 2	37	924 306 202	2	Ball bearing
16	941 210 008	1	Star knob	38	906 000 350	2	Circlip
17	900 008 001	1	Nut	39	105 000 020	1	Broom plate
18	105 000 124	1	Threaded 100mm	40	105 000 025	1	Side broom
19	105 000 125	1	Gullybrush arm part 3	41	905 208 251	1	K-disk
20a	903 610 050	1	Slotted bolt	42	921 110 185	1	Drive belt 10x1850
20b	901 910 050	1	Square slotted bolt	43	105 000 131	1	Drive belt guidance
21	905 110 000	2	Washer				
22	900 010 002	2	Locknut				

Parts catalog

Option: Lighting elements

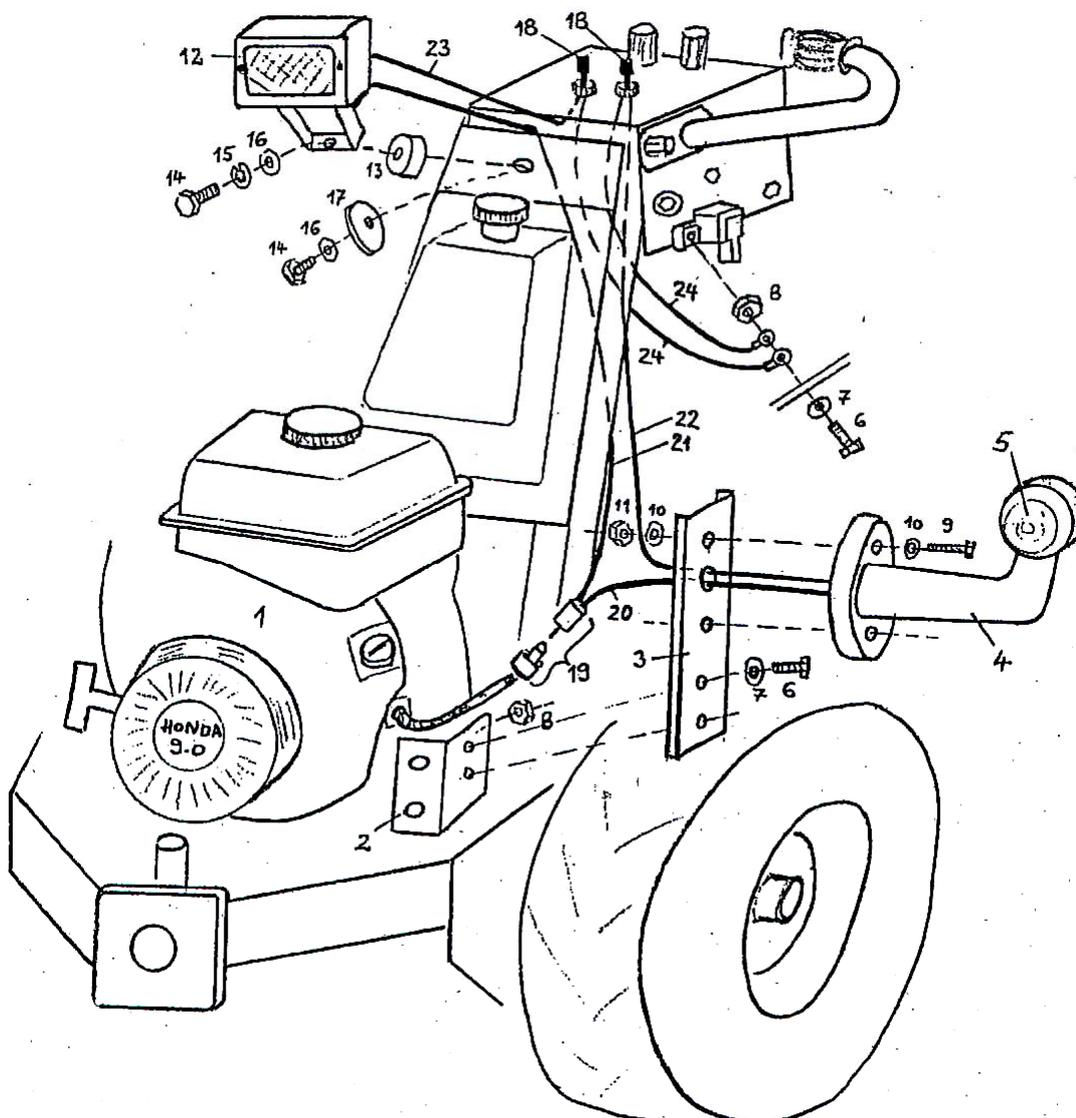

Nr.	Bestell-Nr.	Anz.	Bezeichnung	Nr.	Bestell-Nr.	Anz.	Bezeichnung
1	920 000 102	1	Hondamotor 9PS+Lichtspule	13	911 010 028	1	Rubber metal buffer
1a	920 000 004	1	Hondamotor 9PS with E-start	14	901 010 016	2	screw
2	700 000 050	1	Owner for hydraulic hoses	15	905 010 000	1	Lock washer
3	700 902 050	1	Lighting support plate	16	905 110 000	2	Wearing part
4	960 070 001	1	lateral. Side light	17	705 561 805	1	Large disk
5	960 072 012	1	Pear 18 Watts, 12 V	18	961 070 005	2	Rocker switch
6	901 008 020	3	Screw	19	960 071 008	1	Fuse holder
7	905 108 000	3	Wearing part	20	700 902 280	1	+ cables to the Begr.leuchte
8	900 008 002	3	Stop nut	21	700 902 281	1	+ cables to the headlight
9	901 005 035	2	screw	22	700 902 282	1	- Cables to the Begr.leuchte
10	905 105 000	4	Wearing part	23	700 902 283	1	- Cables to the headlight
11	900 005 002	2	Stop nut	24	700 902 284	2	Mass - cables
12	960 070 002	1	Work slip thrower				