

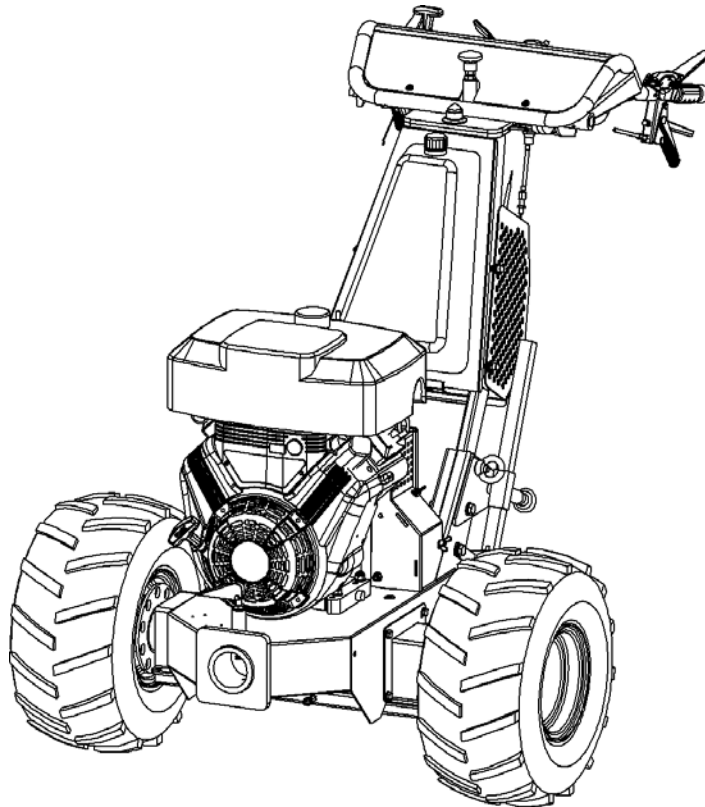

Original Operating Instructions

Hydrostatic Two Wheel Tractor UBS Master



Order number: B00001 From machine No: 43470 R01 Stand: 03.01.2012



Manufactures by
Kersten Arealmaschinen GmbH
Empeler Straße 95
D - 46459 Rees
www.kersten-maschinen.de



Distributed in UK by
Kersten (UK) Ltd Tel. 0118 986 9253
Progres House 39 Boulton Road
Reading, RG2 0NH
www.kerstenuk.com - info@kerstenuk.com

1	LETTER	3
2	ABOUT THIS INSTRUCTION MANUAL	4
2.1	BEFORE COMMISSIONING	4
2.2	NOTES ABOUT THIS MANUAL	4
3	SAFETY INSTRUCTIONS FOR HYDROSTATIC SINGLE TOWERS	5
3.1	INTENDED USE	5
3.2	GENERAL SAFETY AND ACCIDENT PREVENTION RULES	5
3.3	USED PICTOGRAMS	9
3.4	WARNINGS AND SAFETY INSTRUCTIONS FOR FILLED LEAD - ACID BATTERIES.....	10
4	DISPOSAL	11
5	WARRANTY.....	11
6	RECOMMENDATIONS.....	11
6.1	LUBRICANTS	11
6.2	FUELS	11
6.3	MAINTENANCE AND REPAIR	11
6.4	INSTRUCTION FOR USE FOR STARTER BATTERIES.....	12
7	THE OPERATION OF THE SELF-OPERATING WORKSTATION	14
7.1	START THE MOTOR.....	14
7.2	TROUBLESHOOTING AND SWITCHING ON THE SIDE DRIVE	14
7.3	STOPPING THE INTERNAL COMBUSTION ENGINE.....	15
7.4	THE STEERING.....	16
7.5	HEIGHT ADJUSTMENT OF THE HANDWOOD.....	17
7.6	SIDE ADJUSTMENT OF THE HANDHOLM.....	17
8	ASSEMBLY.....	18
8.1	ASSEMBLY OF THE ATTACHMENT	18
8.2	ASSEMBLY OF HAND PROTECTION	19
8.3	MOUNTING OF THE GRID WHEELS	20
9	GENERAL INFORMATION ON LOADING AND TRANSPORT INFORMATION	21
10	MAINTENANCE.....	22
10.1	GENERAL MAINTENANCE INSTRUCTIONS	22
10.2	DAILY MAINTENANCE.....	22
10.3	MAINTENANCE AFTER 20 HOURS OF OPERATION OR LONGER SERVICE LIFE.....	23
10.4	MAINTENANCE AFTER 100 HOURS OF OPERATION	23
10.5	STORAGE	23
10.6	CHECKING THE BELT TENSION VOLTAGE FROM THE SIDE DRIVE	24
11	TECHNICAL SPECIFICATIONS	25
12	WIRING PLAN SECURITY DEVICE	27
13	MALFUNCTION AND THEIR REMEDY	28
14	EC DECLARATION OF CONFORMITY	31

1 Introduction

Dear Customer,

Thank you for choosing a quality product from Kersten.

This product has been manufactured according to the most up-to-date production methods and extensive quality assurance measures, because only when you are satisfied with your device, our goal is reached.

Before using this machine or implement for the first time, please read this manual thoroughly and thoroughly.

If you do not understand any of the information contained in this safety data sheet or the product-specific installation or operating instructions, please contact your sales representative or the machine manufacturer directly.

Keep this manual handy. If necessary, you can read important information and instructions.

Have fun with your Kersten - device wishes you

Dipl.- Ing. (FH) Robert Bosch

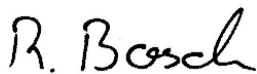

Managing Director

2 About this manual

The machine or implement is subject to technical progress. All information, illustrations and technical data are up-to-date at the time of publication. Changes in the sense of technical progress are reserved to the manufacturer at any time.

Therefore, no claims can be derived from the information and illustrations in this booklet.

2.1 Before commissioning



Since self-propelled implements and attachments can cause serious accidents or hazards if used improperly, the first time the Kersten implement is commissioned, it must be instructed by competent and authorized persons absolutely necessary. The best way to familiarize yourself with its basic functions and its handling is to choose a free and level terrain for your first trip

- **You reduce the risk of accidents on your part or third parties!**

For further information and difficulties of any kind, please contact the dealer, importer or directly to the manufacturer.

- **Be sure to read the safety instructions on the following pages!**
- **Read the operating instructions before commissioning!**
- **Pass on all safety instructions to other users!**

2.2 Notes on this operating manual

- Enumerations are marked with eye-catching points.

Example:

- Text
- Text

- Instructions are marked according to the order in which they are to be executed.

Example:

1. Text
2. Text

3 Safety instructions for hydrostatic towed tractors

The most important safety instructions in this manual cannot cover all possibilities. It goes without saying that common sense and caution are factors that are not built into a machine but must be brought by the person who uses and maintains the machine.

In order to keep the accident risk as low as possible, please observe the following subchapters.

3.1 Intended use



- The towing vehicle as well as the devices approved by the manufacturer are suitable for the respective usual or common use and work in the agriculture and forestry, as for example. Green area and plant maintenance and built for winter service.
- Any other use is considered improper use. The manufacturer is not liable for damage resulting from this, the risk being solely borne by the operator.
- Proper use also includes compliance with the operating, maintenance and service conditions specified by the manufacturer.
- The towing vehicle may only be used, maintained and repaired by persons familiar with it and aware of the dangers.
- The relevant accident prevention regulations as well as the other generally recognized safety and occupational health rules must be observed.
- Unauthorized modifications to the machine lead to the exclusion of liability of the manufacturer for the resulting damage.

3.2 General safety and accident prevention regulations

3.2.1 Basic rules



- In addition to the instructions in this operating manual, observe the general valid safety and accident prevention regulations!
- The towing vehicle may not be operated by persons under the age of 16, not even under the supervision of a
Adults, be served! Children and adolescents should be instructed not to play with the device.
- Only trained personnel or persons may use this machine!
- When using public traffic routes, observe the relevant regulations!
- The tiller is not approved for public transport.
- The clothing of the user should be tight. Avoid loose-fitting clothing and wear sturdy hoes or safety shoes!
- Only work in good visibility and light conditions!
- The attached warning and information signs provide important information for safe operation; the attention serves your safety!
- For transport on motor vehicles or trailers outside the area to be machined, the motor must be switched off!
- Be careful with rotating tools - safety distance!
- Be careful with trailing tools. Wait for work on these until they stop completely!
- There are crushing and shearing points on driven parts!
- The transport of persons and objects is prohibited!
- Driving behavior, steering and possibly braking capability as well as tilting behavior are influenced by mounted or attached devices and load. For this reason, only implements approved by the manufacturer may be used. The working speed must be adapted to the respective conditions.
- Do not make any changes to the engine's upper idle speed. Too high a speed increases the risk of accidents.
- Unauthorized conversions that endanger the operational safety of the machine are prohibited!

3.2.2 Work and danger area



- The user is responsible to third parties in the work area!
- Staying in the danger area of the machine is prohibited!
- Check the near range before starting up. Pay special attention to children and animals. Ensure sufficient visibility!
- Before starting work, remove foreign objects from the surface to be worked. Pay attention to other foreign objects during work and eliminate them in good time.
- When working in enclosed areas, the safety distance to the border must be maintained so as not to damage the tool.
- When working in the immediate vicinity of public roads and paths, these should not be approached if possible, as there is a risk of injury to third parties due to flying objects.
- When working on public roads and squares or in the immediate vicinity, warning and danger signs should be set up in order to attract the attention of third parties.

3.2.3 Before starting work



- Before starting work, please familiarize yourself with all the devices and actuators as well as their function and make sure that all safety devices are properly installed and in the protective position! It is too late during the work assignment!
- Above all, learn how to stop the engine quickly and safely in an emergency

3.2.4 Starting the machine



- When starting the motor, all drives must be switched off!
- Do not run the engine indoors!
- Do not step in front of the single-axle tractor or the implement to start the engine.
- Do not use jumper fluids when using electric jump start (jumper cable). There is a danger of explosion!

3.2.5 During operation



- Never leave the operating position on the guide rail while driving!
- Never adjust the operating handle while driving - risk of accident!
- The transport of persons and objects is prohibited!
- If, for example, the attachment has caught a foreign object and blocked it, stop the engine and clean the attachment with a suitable tool! Always switch off the engine when handling or cleaning the implement!
- Do not leave the operating station until all tools of the attachment have come to a standstill!
- In the event of damage to the self-propelled implement or attachment, stop the engine immediately and have the damage repaired.
- If the steering fails, stop the self-propelled implement immediately and stop the engine. Have the fault rectified immediately.
- If there is a risk of slipping on sloping ground, the implement carrier must be secured by an escort with a pole or a rope. The escort must be located above the vehicle at a sufficient distance from the work tools! For the helper, it is recommended to wear crampons.
- If possible, always drive across (horizontally) to the slope!
- Only drive on rough and dry ground on steep slopes! Moisture and rain increase the risk of slipping out and slipping.
- On steep slopes, lattice wheels or sprockets must be used to prevent the tractors from slipping off.
- In emergency situations, if, for example, the machine slips sideways in the slope, always release the handles! You as an operator do not manage with their physical strength to prevent the cultivators on slipping and are otherwise carried away.

3.2.6 Leaving the machine



- When stopping the machine, close the fuel cock (if present)!
- By using wheel chocks or, if necessary, by applying the parking brake, secure the machine from rolling away when leaving the vehicle.
- Secure the device against unauthorized use!
- Switch off the engine and, if present, remove the ignition key or the spark plug connector!
- Never leave the machine unattended while the engine is still in operation!

3.2.7 Screw connections and tires



- When working on the wheels, make sure that the device is safely parked and secured against rolling away!
- Regularly check nuts and bolts for tightness and retighten if necessary.
- Repair work on the tires must only be carried out by qualified personnel and with suitable mounting tools!
- If the tire pressure is too high there is a risk of explosion!
- Check the air pressure regularly!

3.2.8 Coupling and uncoupling attachments



- Attach and remove attachments only when the engine is off and the PTO is off.
- When replacing attachments and their parts, use suitable tools and wear gloves.
- When mounting and dismantling, bring the required support equipment into the respective position and ensure sufficient stability.
- Secure the rear-mounted tow tractor with an attachment to prevent it from rolling (parking brake, wheel chocks).
- When attaching attachments, there is a risk of injury (crushing). Special care is necessary.
- Attach implements according to regulations and fix in the prescribed places.

3.2.9 Maintenance, cleaning and repair work



- Do not carry out maintenance and cleaning work on the running engine!
- When working on the engine, always remove the spark plug connector.
- If guards and working tools are subject to wear, they must be checked regularly and replaced if necessary.
- Damaged cutting tools must be replaced.
- When replacing cutting tools, use suitable tools and wear protective gloves.



- Only use original spare parts from the manufacturer, as these comply with the technical requirements and thus the risk of accidents is minimized!
- Cleaning with the high-pressure cleaner should be carried out so that the water jet is not held directly in bearings, turned parts, grease nipples, shaft seals, wheel hubs, etc. After each cleaning with the high-pressure device, the lubrication points must be re-greased. In the case of infringement, the right to guarantee expires!
- Check the moving parts for ease of movement and regresses if necessary!
- After maintenance and cleaning work, be sure to replace the guards and put them in the protective position!
- To avoid the risk of fire, keep the machine clean!
- Regularly check nuts and bolts for tightness and retighten if necessary.
- When carrying out maintenance, cleaning and repair work on the lifted device, always make sure that it is protected by suitable support elements!
- Before carrying out any repairs, make sure that the hydraulic system is depressurized, because fluids under pressure can penetrate the skin and cause serious injuries! Therefore See a doctor immediately - danger of infection!
- Repairs may only be carried out by qualified personnel.
- When working on the electrical system, always remove the earth strap from the battery!
- Check the hydraulic hose lines for damage and aging at regular intervals and replace if necessary.
- When welding the tractor or mounted equipment, disconnect the battery.
- Repairs such as welding, grinding, drilling, etc. must not be carried out on supporting and other safety-related parts such as frames, axles, etc.!

3.2.10 Engine, fuel and oil



- Before refueling, switch off the engine and remove the ignition key (if available)!
- Do not top up with fuel and do not spill fuel (use a suitable refilling aid). If necessary, take up spilled fuel immediately.
- Dispose of oils, fuels and filters separately and properly!
- When handling fuel, caution is required, increased risk of fire. Never refuel near open flames, hot engine parts, and sparks when flying. Do not smoke when refueling!

3.2.11 Electrical system and battery



- When working on the electrical system, always disconnect the battery (negative pole) (if present).
- Make sure the connection is correct - first positive pole and then negative pole!
- Be careful with battery gases - Explosive!
- Avoid sparks and open flame near batteries.
- Take care when handling battery acid - corrosive!
- Always provide the positive pole with the intended cover or terminal protection cap.
- Caregivers of pacemakers must not touch the live parts of the ignition system while the engine is running!

3.3 Pictograms used

Explanation of the pictograms used:



Before commissioning read and observe the operating instructions and safety instructions.



Switch off the engine and remove the spark plug connector before carrying out any repair, maintenance or cleaning work.



Never open or remove protective devices while the engine is running!



Touch machine parts only when they have come to a complete stop.



Danger from passing parts while the engine is running - keep safety distance.



Follow the instructions in the technical manual.
Smudge!!

3.4 Warnings and safety instructions for filled lead - acid batteries



- Follow the instructions on the battery and in the operating instructions.



- Use eye protection.



- Keep children away from acid and battery.



Explosion hazard:

- When charging batteries, a highly explosive bang mixture is produced, so please note the following:



- Fire, sparks, open light and smoking prohibited.
- Avoid sparking when handling cables and electronic devices, as well as through electronic charging.
- Avoid short circuits



Burn Hazards:

- Battery acid is highly corrosive, therefore:
- Wear protective gloves and eye protection.
- Do not tip the battery, acid can escape from the degassing openings.



First aid:

- Acid splash in the eye; immediately rinse with clear water for several minutes. Then seek medical attention immediately.
- Acid splashes on the skin or clothing; Immediately neutralize with an acid converter or soapy water and rinse with plenty of clear water.
- In case of drunk acid, consult a doctor immediately.



Warnings:

- Do not expose batteries to direct daylight unprotected.
- Discharged batteries can freeze, therefore store frost-free.



Disposal:

- Hand over used batteries at a collection point.
- During transport, the following instructions for use must be observed.
- Never dispose of old batteries in the household waste.

Pb

4 Disposal

The equipment must be disposed of in accordance with local, state, or local regulations.

Depending on the material, you can dispose of the parts as residual waste, special waste or recycling. The company Kersten Arealmaschinen GmbH assumes no disposal.

5 Warranty

The device is accompanied by a sales message, which among other things determines the time of the start of the warranty period. When selling the device, please complete the sales message completely and send it back to us within 14 days. If warranty claims are asserted without us having a sales message, no warranty service will be provided.

Warranty claims should be submitted promptly, but no later than six weeks after the occurrence of the damage, giving details of the purchase data, otherwise no warranty service will be provided. Complaints must be confirmed by the company Kersten Arealmaschinen GmbH. Wear parts are excluded from the warranty. Furthermore, the warranty expires due to improper operation, when performing no or incorrect maintenance work, when using inadmissible equipment and when using non-original spare parts.

6 Recommendations

6.1 Lubricants

For engine and gearbox, use the specified lubricants (see under "Technical data").

For "open" lubrication points or nipple points we recommend using bio lubricant oil or bio lubricant grease. With the use of bio lubricant, you act ecologically correct, protect the environment and promote the health of people, animals and plants.

6.2 Fuels

The built-up B & S or Honda engine can be easily operated with commercial unleaded normal and premium gasoline and leaded premium gasoline.

Do not add oil to the gasoline.

If unleaded petrol is used for the environment, engines that are to be decommissioned for more than 30 days should have their fuel drained completely to avoid resinous residues in the carburetor, fuel filter and tank, or to add fuel stabilizer to the fuel.

6.3 Maintenance and repair

Your dealer has trained mechanics who perform proper maintenance and repair. You should only carry out major maintenance work and repairs yourself if you have the appropriate tools and knowledge of machines and internal combustion engines.

6.4 Instructions for Use for Starter Batteries

1. Removal and installation of the battery

- Before removing the battery, switch off the engine and all power consumers.
- Avoid short circuits due to tools.
- When removing, first disconnect the negative pole (-), then the positive pole (+).
- Clean battery terminals and pole terminals and treat with acid-free grease.
- Clean the footprint / support before installing the battery.
- Tighten the battery firmly.
- When installing, first connect positive pole (+), then negative pole (-).
- Make sure that the pole terminals are secure.
- Leave at least one gas outlet unlocked.
- This also applies to the return transport of used batteries.

2. External loading

- Read and follow the operating instructions of the charger manufacturer!
- Check electrolyte level before charging and level if necessary.
- Disconnect the battery cable and remove the battery from the vehicle.
- Ensure good room ventilation.
- Use only suitable DC chargers.
- Connect the positive pole (+) of the battery to the plus output of the charger. Connect negative pole (-) accordingly.
- Only switch on the charger after the battery has been connected and switch off the charger after charging.
- Charging current should be 1/10 Ah of battery capacity.
- Interrupt the charge if the acid temperature exceeds 55 °C.
- Battery is fully charged if charging voltage does not increase within 2 hours.

3. Maintenance

- Keep the battery clean and dry.
- Do not use any improvers.
- Do not open the battery.
- If the starting power is insufficient, recharge the battery.

4. Star Help

- Use only standardized jump leads and observe their instructions for use.
- Use only batteries of the same nominal voltage.
- Switch off the engine from the helping vehicle.
- First connect both positive terminals (+) with the red jumper cable. Then connect a pole tongs to the negative pole (-) of the dispenser battery. Then clamp the second pole on one of the bare spots of the needy single-axle tractor.
- Start the helping vehicle, then max. The engine of the auxiliary towing vehicle max. Start 15 seconds.
- Disconnect the cable in reverse order.

5. Decommissioning

- Store the battery in a cool place.
- When decommissioning, disconnect the negative pole (-).
- Regularly check the charge status of the battery and recharge if necessary.

7 Operation of the self-propelled implement

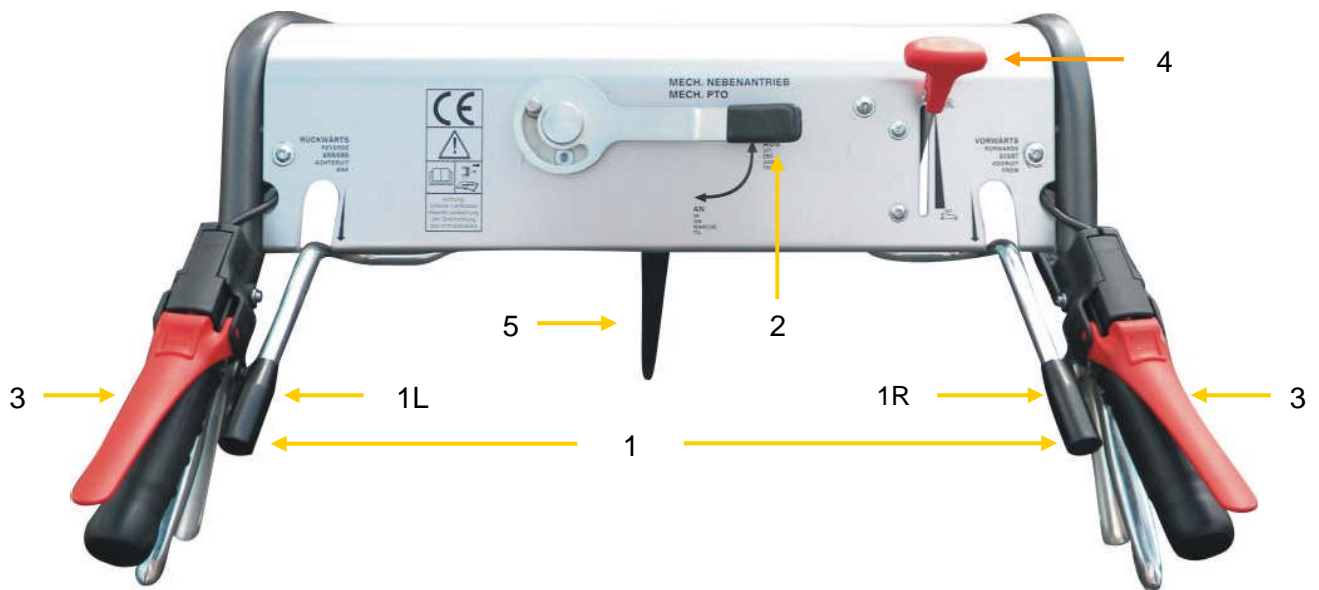

Figure 7.1

7.1 Start the engine

- To start the engine, the drive lever (Fig.7.1, item 1) must be in the horizontal position and the PTO lever (Fig.7.1, item 2) must be in the "off" position.



If these are not in the position described above, the ignition of the engine is interrupted, and the engine does not start.

- During the starting process it is forbidden to operate the Deadman switch (Fig.7.1;
- Observe the respective operating instructions of the engine manufacturer to start the engine

7.2 Starting and switching on the auxiliary drive

The best way to familiarize yourself with the basic functions of a self-propelled implement is to choose a free and level terrain for your first trip.



- Press the throttle lever (Fig.7.1, item 4) about 1/3.
- Press the dead man switch (Fig.7.1, Pos.3) down and keep it pressed.
- Make sure that nobody is in front of and behind the machine!
- On both sides of the handlebar there is a driving lever (Fig.7.1, Pos.1L and 1R), which are connected by a common pivot point and thus form a common driving lever (Fig.7.1, Pos.1). When a drive lever is actuated, the opposite drive lever performs an opposite movement, so that the operation of the drive lever is similar to a rocker.
- For forward driving, the right-hand drive lever (Fig.7.1, item 1R) is pressed down by the right thumb. The more the drive lever is pressed down, the faster the machine moves. In order to reduce the speed or to stop the machine, push down the raised lever (Fig.7.1, item 1L) with your left thumb.
- If the individual drive levers (Fig.7.1, items 1L and 1R) are at the same height or in a horizontal position, the machine is stationary.



- For the reverse drive, the left driving lever (Fig.7.1, item 1L) is pressed down by the left thumb. The more the drive lever is pressed down, the faster the machine moves. In order to reduce the speed or to stop the machine, push down the lever swung upwards (Fig.7.1, item 1R) with your right thumb.
- In order to select the direction of travel and the appropriate driving speed, the hands need not be removed from the handles!
- The force that needs to be applied with the thumb to operate the control lever can be adjusted to the conditions of use. For light maintenance work, the brake resistor for the self-holding of the driving lever may be smaller than, for example, when mowing on a slope. If the frictional resistance is too small, then the driving lever retracts itself in the direction of the neutral position. The lever to set the correct braking resistor is located in the center and below the control panel (see Fig.7.1, item 5).
- Use the throttle lever (Fig.7.1, item 4) to regulate the engine speed and thus also the driving speed. Always try to drive with the lowest speed required, this protects material and the environment.
- The attachment machine is switched to "on" or "off" with the lever (Fig.7.1);
- Switching on the implement is only permitted on a free or already worked area!
- It is not permitted to switch on the implement outside the working area!
- Never operate the attachment when children or animals are in the work area.
- If, when turning on the attachment, you notice that the tool is not turning up and you hear a noise from slipping V-belts, the attachment must be switched off immediately. If the tool is engaged, the initial torque is too high. If possible, switch on the machine without load. If necessary, check the tension of the tension spring on the Bowden cable.

7.3 Parking the internal combustion engine

- Before switching off the combustion engine, make sure that the control lever (Fig.7.1, item 1) is in the horizontal position and the PTO lever (Fig.7.1, item 2) is in the "off" position,
- Move the throttle lever (Fig.7.1, item 6) to neutral and allow the engine to idle for approximately one-half minute.
- Set the engine off switch located on the internal combustion engine to "0".
- Close the fuel tap.
- Secure the towing vehicle against unauthorized use and, if necessary, remove the ignition key.
- By using wheel chocks or if necessary by operating the parking brake, secure the device against rolling away when leaving the vehicle.

Tip:



In case of prolonged downtime, do not stop the engine with the "Engine off switch", but close the fuel cock and let the engine run until it comes to a standstill by itself. Thus, the carburetor is empty, and no gumming can occur. This procedure must not be carried out in confined spaces, otherwise there is danger of suffocation. Basically, pay attention to adequate ventilation!

7.4 The steering

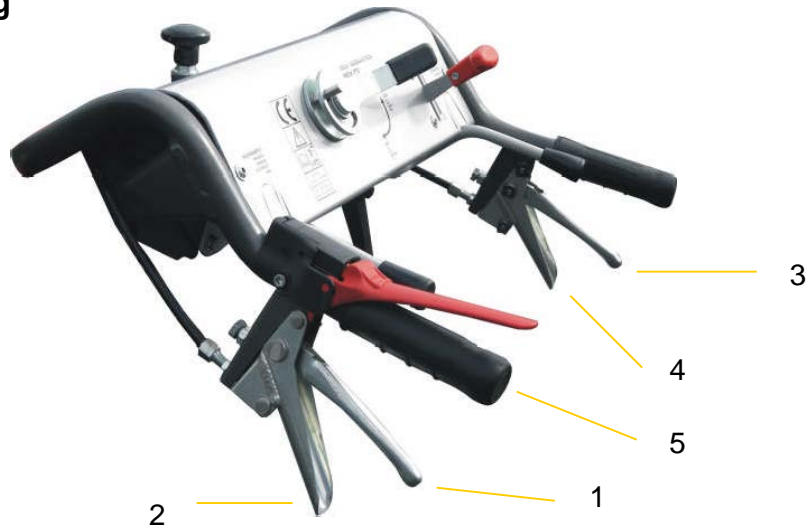

Figure 7.2



- The implement is driven by two-wheel motors, which are controlled separately.
- The single-wheel drive allows the wheels to rotate at different speeds and in different directions. This makes it possible to drive very tight bends and, if necessary, to stop the machine quickly or drive backwards.
- As shown in Figure 7.2, a first steering lever (Pos. 1 or Pos. 3) and a second steering lever (Pos. 2 or Pos. 4) are arranged on the control panel on each handle.
- If, for example, a left-hand drive is to be initiated, this can be done by actuating the first steering lever (Fig.7.2, item 1) on the left handgrip (Fig.7.2, item 5). The more the first steering lever is pulled through, the smaller the turning circle becomes, until finally the left wheel is blocked. The right wheel is not affected in this steering maneuver and maintains its speed. If necessary, by moving from the first steering lever to the second steering lever (Fig.7.2, item 2), the left wheel can be moved in the reverse direction, whereby the turning circle can be reduced so that the motor mower rotates about its own axis. There is a proportional behavior in both functions of the steering levers. This means that the further the second steering lever is pulled through, the faster the left wheel turns out of the blocked state in the opposite direction of travel.
- When the two first steering levers (Fig.7.2, Pos.1 and Pos.3) are actuated at the same time, the drive unit stops, while the second steering levers (Fig.7.2, Pos.2 and Pos.4) are in the reverse direction at the same time emotional.
- The control device with two steering levers on each side also constitutes a safety device, since it is necessary to engage the two steering levers in a deliberate manner in order to change the direction of rotation of the relevant wheel.

For sudden dangers moments:

- In emergency situations, the operation of the two first steering levers (Fig.7.2, Pos.1 and Pos.3) can be used to immediately stop the machine. The traction drive itself is switched off by the subsequent actuation of the driving lever (Fig.7.1, item 1) in the horizontal position. Following this, the two steering levers can be released.
- Release the dead man switch (Fig.7.1, item 3). This shuts off the engine and brakes the wheels. At maximum speed, the machine comes to a standstill after a few meters.

7.5 Height adjustment of the hand rail

The hand rail is adjustable in inclination angle to ensure the operator an ergonomically optimal working height.

1. Loosen the rotary knob (Fig.7.3, item 1).
2. Shake the handgrip until the toothed washers are free.
3. Bring the handrail to the desired height and insert it into the appropriate catch.
4. Retighten the twist grip (Fig.7.3; item 1).



Figure 7.3

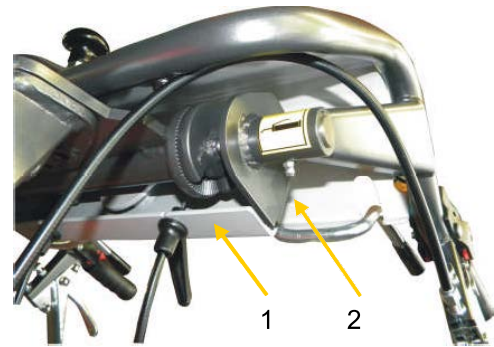

Figure 7.4

Note:



The angle of inclination of the handrail is fixed by means of toothed discs (Fig.7.4, Pos.1). In order to enable an adjustment, a toothed disk is axially displaceable. To permanently ensure that it can be moved, it must be lubricated every 20 operating hours. The lubrication point (Fig.7.4, item 2) is located in the direction of travel on the left below the control console.

7.6 Side adjustment of the hand rail

The handrail can be swiveled out of its normal position (middle position) by about 30° to the left or to the right.

1. Pull up and hold the knob (Fig.7.5, item 1).
2. Swivel the handrail to the left or right to the desired position.
3. Release the knob (Fig.7.5, item 1) and move the handrail slightly to the left and right until the locking pin engages.



Figure 7.5

8 Assembly

8.1 Assembly of the attachment

- To mount an attachment, the attachment and attachment tube on the drive unit must be clean and well-lubricated (see Figure 8.1).
- The coupling of the attachment and the receiving tube of the drive unit must be at the same height to allow them to be pushed together. For this purpose, parking supports are available on some attachments, where the appropriate height can be adjusted.
- When assembling, it is important to note that the clutch driver (Plastic star) is located in one of the two coupling halves.
- Pull up on the locking lever and lift up the locking lever.
- If the attachment of the attachment can-not be pushed completely into the pick-up tube, then the teeth of the two coupling halves may be opposite each other. By switching on the power take-off and by slowly pulling in the starter cable of the engine, the drive shaft continues to rotate, allowing the further drive in.
- Lower the locking lever again and check that the locking pin is fully engaged.

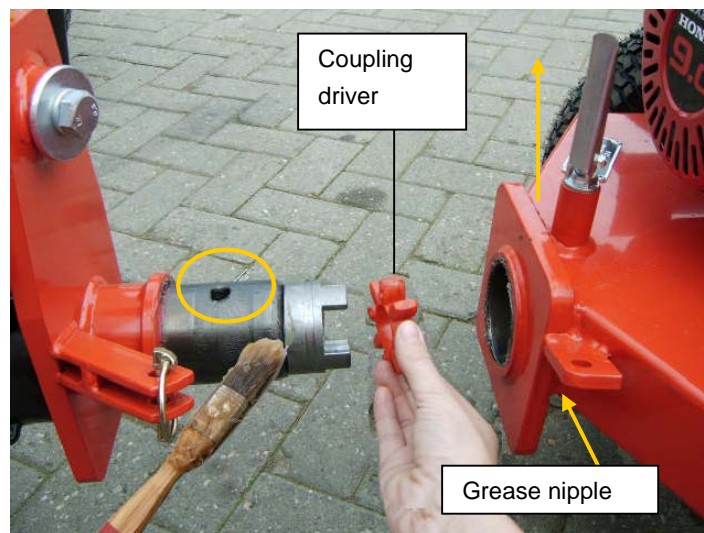

Figure 8.1

8.2 Assembly of the hand guard

The installation of the handguard is described in more detail below and illustrated in Figure 8.2.

1. To install the left-hand guard, place the supplied drilling template (Fig. 8.2, item 1) on the hand spar (Fig. 8.2, item 2) and drill two 6.5 mm holes.
2. Screw on the left mounting bracket (Fig. 8.2, Pos. 3) with 2 M 6 x 20 screws, 2 body washers and 2 lock nuts.
3. Fasten the hand guard with 2 M6 x 20 screws, 2 large washers and 2 lock nuts.
4. Perform the same steps for mounting the right-hand guard.

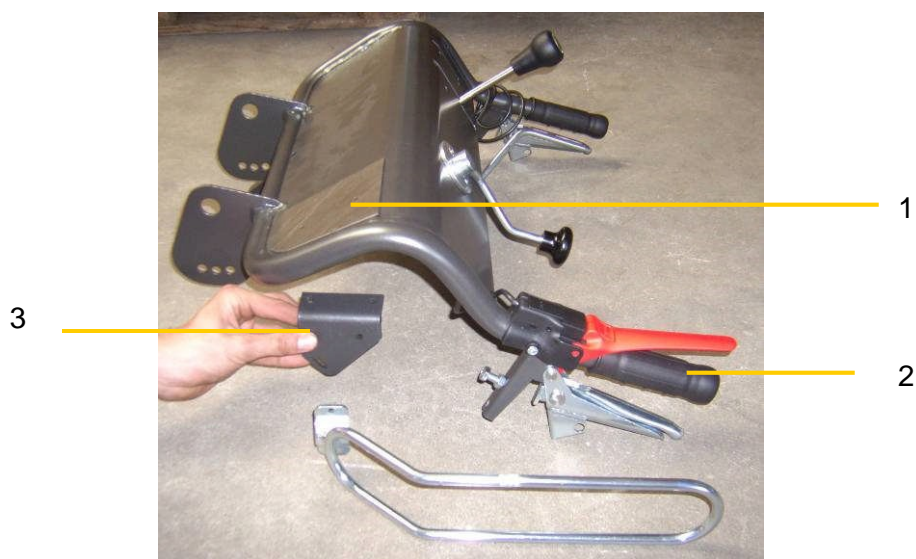

Figure 8.2

8.3 Assembly of the lattice wheels

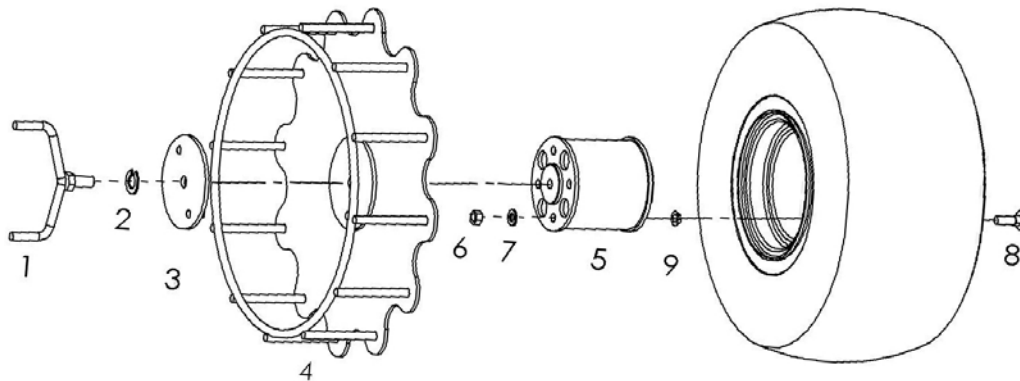

Figure 8.3

For the subsequent installation of the lattice wheel set, the hitch hubs (Fig.8.3, item 5) must first be mounted on both sides of the self-propelled implement.

- Raise the rear part of the self-propelled implement with appropriate tools until the drive wheels are unloaded and free to move. The lifted machine is supported by a hard base - e.g. Squared timbers - to be secured in such a way that unintentional falling is prevented.
- Loosen the wheel nuts on both sides, remove the drive wheels and remove the existing wheel bolts from the wheel hubs. These are replaced by the supplied wheel bolts M12 x 50.
- First insert the drive wheel and then the supplied attachment hub of the mesh wheel onto the existing wheel hub. Between the drive wheel and the attachment hub, the Limes rings (conical washers) must be inserted so that the drive wheel is firmly centered on the wheel hub. The drive hub and the attachment wheel are firmly screwed in using the stoppers provided. Here, the stop nut is inserted into the 19'er nut and guided by means of a long extension through the mounting hub to the wheel bolt.
- The lattice wheels are mounted on soft ground immediately before use. Since the grids are larger in diameter than the drive wheels, the machine or the drive wheels must be on a solid surface, for. stand a wooden block.
- The sprocket wheel is put on the hub and fixed by the driving plate (Fig.8.3; Pos.3).
- Finally, secure the mesh wheel and drive plate with the thumbscrew (Fig.8.3; In order to avoid unintentional loosening of the thumbscrew, there should be a spring washer (Fig.8.3; Pos.2) in front of the thumbscrew.

9 General instructions for load securing and transport

- Pay attention to the trailer load of the towing vehicle and the permissible total weight of the trailer!
- Suitable loading ramps with sufficient load-bearing capacity must be used for loading the machine.
- The ramps must be secured against slipping.
- The machine must be secured against rolling during transport.
- On the handlebar pockets of the self-propelled implement (Fig.9.1, item 1) and on various attachments (Fig.9.2, item 1) there are ring eyes that can be used for lashing.



Figure 9.1

1

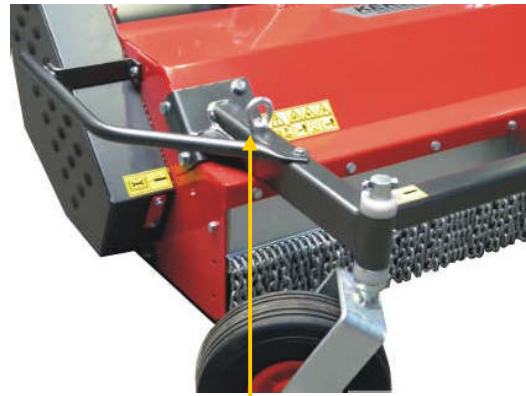

Figure 9.2

1

- If present, apply the parking brake so that the drive wheels are locked.
- Switch off the engine and close the fuel tap.
- Before unloading the machine make sure that there is no obstacle immediately before the ramps on the ground, otherwise there is a risk of collision. When unloading several machines, these are far enough to drive out of the loading zone.

10 Maintenance

10.1 General maintenance instructions



- Personal injury or damage to the machine may occur.
- Check all safety-related parts before every use of the machine.
- Oil change intervals must be carried out according to the recommendations of the respective engine manufacturer.
- Check the hydraulic connections for leaks before each use.
- **High pressure leaking fluids (such as hydraulic oil and diesel fuel) can penetrate the skin and cause serious injury! Therefore, seek medical attention immediately - risk of infection!**
- The self-propelled implement is powered by biodegradable oil.
- The machine must be regularly serviced.
- Dispose of oils, fuels and filters separately and properly!
- When working on the electrical system, disconnect the earth connection from the battery!
- Repairs, maintenance and cleaning work as well as the elimination of malfunctions must always be carried out with the drive switched off and the engine stationary. Remove ignition key or spark plug connector! After carrying out this work, replace all protective devices!
- If the machine is transported in a different way than with its own drive, this must be done with the motor switched off!
- Regularly check nuts and bolts for tightness and retighten if necessary.
- When carrying out electrical welding work on the tractor and attached equipment, disconnect the cables at the generator and at the battery!
- Only use original spare parts from the manufacturer!
- After the first 5 hours of operation, check all screw and bolt connections.
- Lubricate or lubricate all moving parts regularly.
- Check hydraulic connections for the first time after 5 operating hours, retighten if necessary.



**Only tightening has no success!
Release a leaking hydraulic fitting first, then move the hose or fitting, and then retighten the fitting.**

10.2 Daily maintenance

- Before each use, the safety elements and moving parts must be checked for wear.
- Check the hydraulic oil level before each use. To do this, unscrew the cap from the tank and visually check whether the oil in the tank easily covers the horizontally arranged plate.
- Below the device holder of the self-propelled implement, there is a grease nipple, which is greased before each use.
- Check the engine oil level before each use.
- Inspect the air pre-filter (if present) and air filter cartridge for dirt if it is very dirty or damaged.
- Check hydraulic connections and lines for leaks and damage.
- Check the air pressure of the drive wheels.
- Carry out a test run before each use.
- Clean the unit after each use.
- Check oil cooler for dirt and clean if necessary.

1. Loosen the pipe clamp on the dirt deflector.
 2. Remove dirt deflector upwards.
 3. Blow out the radiator from bottom to top!
 4. Clean dirt deflector and install again.
- To ensure the cooling of the motor, always make sure that no dirt is present in the air intake area of the engine and on the intake grille.



Even during use, regular checks are mandatory to avoid overheating the engine!

10.3 Maintenance after 20 operating hours or longer downtime

- At regular intervals and at the beginning and end of the season, the moving parts of the unit must be greased or oiled.
- • For daily work with heavy attachments, such as Flail mower, once a week the implement must be disconnected from the self-propelled implement and the coupling driver (plastic star) checked for damage. Before rebuilding the attachment, clean the connection and re-grease it as described in chapter 8.1.
- • Lubricate or lubricate Bowden cables as required.
- • First change hydraulic oil and filter after 20 operating hours, then every 100 operating hours. Change the hydraulic oil filter at the same time interval as the oil change. (used oil type see chapter for technical data)
- • Clean the air pre-filter (if present) at the latest after 25 operating hours and in very dusty conditions after a few hours.
- • Replace the air pre-filter (if present) and the air filter cartridge if they are very dirty or damaged.

10.4 Maintenance after 100 operating hours

- Fan housing after every 100 operating hours or min. Take off once a year - preferably before the season - and clean the cooling fins on the cylinder and cylinder head as well as the baffles necessary for air circulation, the cooling air filter and the oil cooler.
- First change hydraulic oil and filter after 20 operating hours, then every 100 operating hours. Change the hydraulic oil filter at the same time interval as the oil change. (used oil type see chapter for technical data)
- Cleaning the spark plug of soot deposits with a wire brush followed by checking the distance between the electrodes. The electrode distance should be approx. 1 mm. Renew spark plugs after 200 operating hours.
- Clean the air filter cartridge at the latest after 100 hours of operation and in very dusty conditions after a few hours.

10.5 Storage

If the machine is not used for a long time, the following measures are recommended:

1.) Perform cleaning

2.) Preserve the motor (observe the instructions of the motor manufacturer)!

- Completely drain fuel or top up fuel tank, add fuel stabilizer to fuel.
- Run the engine for approx. 1 minute.
- Add one teaspoonful (approx. 0.03 ltr.) Of engine oil to the spark plug opening and then slowly crank the engine.
- Reinstall the spark plug and do not attach the spark plug connector. Pull on the starter handle until the compression resistance is felt, thus the valves are closed.

- Every two to three weeks, crank the engine slowly and pull it again until the compression resistance is felt.

3.) Jack drive wheels

- Using wooden blocks, jack up the machine so that the drive wheels are not resting on the ground. Pay attention to stability!

4.) Subordinate machine

- To prevent corrosion, protect the machine from weathering. Do not store the machine in damp rooms, artificial fertilizer warehouses or stables.

5.) Cover the machine with a cloth or similar.

10.6 Checking the V-belt tension from the PTO

To prevent the V-belts from slipping or burning, they must be sufficiently tensioned when switched on. The tension on the V-belts is provided by a tension spring, which is located between the activation lever and the Bowden cable under the control console.

As long as the stroke of the shift lever is greater than the distance traveled by the tension roller, a change in length of the tension spring takes place. The greater the change in length of the tension spring, the greater the ultimate bias of the V-belts. On the one hand, the tension spring ensures sufficient pretension of the V-belts and, on the other hand, it also serves as a buffer for possible length changes of the V-belts.

When the PTO is switched on, the length change of the tension spring should be min. 4 mm.

The following relationship applies:

V-belts are lengthening => spring travel is decreasing => preload is decreasing => slipping of V-belts => burning of V-belts



V-belts that have burned must be replaced by new ones, as they can no longer transmit any torque! Only use original manufacturer V - belts!

11 Technical data

Specifications - 18 hp petrol engine	
Engine	Briggs & Stratton Vanguard four-stroke two-cylinder engine
Power	13.4 kW (18 HP)
Max. torque	40.7 Nm / 2,300 min ⁻¹
Capacity	570 cc
Upper idle speed	3,300 min ⁻¹
Spark plug	Bosch FR8DC Champion RC12YC
Engine oil	approx. 1.7 l multigrade oil
Fuel	SAE 10W-40 API-SE / SF or higher at ambient temperature -15°C to + 45°C SAE 5W-20 API-SE / SF or higher at ambient temperature -25°C to + 15°C
Fuel tank	see chapter "Recommendations"
Fuel consumption	about 8.5 l
Air filter	3.8 l / h - 3,600 min ⁻¹ under continuous load - 3.0 l / h at 75% continuous load
Starting device	Dry filter element with foam pre-filter
E-starter battery	Recoil

Technical data - General	
Type	UBS Hydro
Hydraulic oil tank	about 10 l
Hydraulic oil	Synthetic Ester Bio-hydraulic oil Avia Synto fluid N68 (recommended)
Viscosity grade according to ISO	VG 68
Max. operating pressure	180 bar
Delivery volume pump	about 18 l / min
Driving speed	0 - 6 km / h step lessly adjustable
Forward / forward	1,350 rpm at 3,400 rpm engine speed
Zapf Elle speed	clockwise - seen clockwise from the front on PTO shaft
Direction of rotation PTO	about 10 liters
Hydraulic oil tank	height adjustable and vibration damped
hand Holm	Fully hydraulic and mechanically operated
Steering: 4.00-8 Block 4.00-8 AS 5.00-10 AS 16x6.5-8 Block 16x6.5-8 AS 18x7.00-8 AS	Guide values (maximum tire pressure 2.5 bar - explosion hazard) 1.4 bar 2.2 bar 2.2 bar 1.9 bar 1.9 bar 2.0 bar
Hand arm vibrations according to DIN EN 12733: 2009	<2.5 m / s ² with flail mower attachment
Sound power level LWA according to DIN 12733: 2009-11-18	
Sound pressure level on the ear according to DIN 12733: 2009	

- Reserve technical changes! -

12 Wiring Diagram - Safety Device

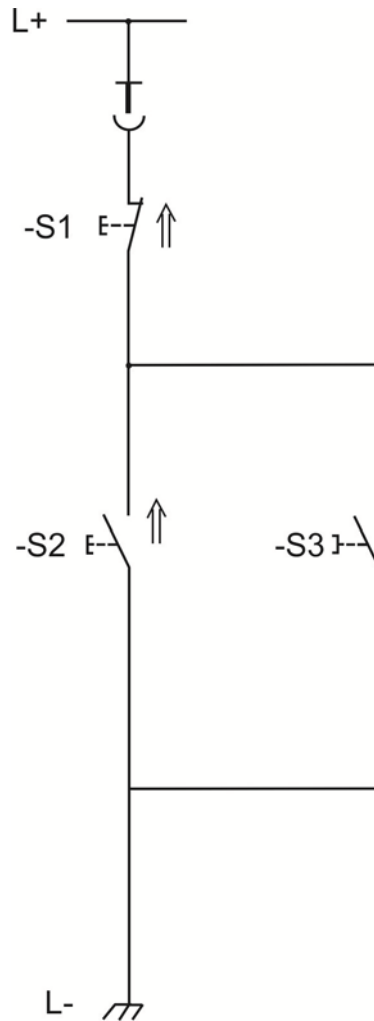

Reserve technical changes!

Name	Use
- S1	Deadman
- S2	Lever
- S3	Hydraulic auxiliary drive
- L+	Ignition coil, engine
- L-	Dimensions

13 Fault cause and remedy



This chapter describes in more detail the most important faults which can occur during operation on the self-propelled implement. Faults which require major intervention must always be rectified by your specialist workshop.

Observe safety instructions!

Malfunction:	Possible cause:	Remedy:
Petrol Engine:		
Gasoline engine does not start	<ul style="list-style-type: none"> - Do not plug the spark plug connector on. - Choke not switched - Motor-off switch on "0" - Safety circuit not in start position - Fuel tank empty or bad fuel - Clogged flue line - Spark plug defective - Engine too much fuel (flooded) - Motor off line defective - False air due to loose carburettor and intake pipe 	<ul style="list-style-type: none"> Plug the plug connector on Choke lever in choke position bring Switch motor off switch to position "I" Switch safety circuit to start position Fill the fuel tank with fresh fuel Clean fuel line Clean, adjust or replace the spark plug Dry the spark plug, clean it and start with FULL THROTTLE Check cable and plug connections Tighten fastening screws
Gasoline engine has dropouts	<ul style="list-style-type: none"> - Engine is running in the CHOKE area - Ignition cable loose - Fuel line clogged or bad fuel - The ventilation in the fuel tank cover is clogged - Water or dirt in the fuel system - Air filter dirty - Carburetor adjusted 	<ul style="list-style-type: none"> Move choke lever to "Operation" position Plug the spark plug connector firmly onto the ignition cable. Secure the ignition cable fastening Fit the spark plug plug firmly onto the spark plug Change fuel filter or fill up with fresh fuel Replace fuel tank cover Drain and clean fuel, refuel with fresh fuel Clean or replace the air filter Adjust carburetor
Gasoline engine gets too hot	<ul style="list-style-type: none"> - Too little engine oil - Cooling air system restricted - Air filter dirty - Carburettor not set correctly 	<ul style="list-style-type: none"> immediately refill engine oil Clean fan grille, internal Clean cooling fins Clean or replace the air filter Adjust carburetor
Gasoline engine has dropouts at high revs	<ul style="list-style-type: none"> - Ignition interval too low - Idle mixture not set correctly 	<ul style="list-style-type: none"> Adjust spark plug Adjust carburetor
Gasoline engine often goes off at idle	<ul style="list-style-type: none"> - Ignition distance too large, Spark plug defective - Carburettor not set correctly - Air filter dirty 	<ul style="list-style-type: none"> Set or replace spark plug Adjust carburetor Clean or replace the air filter

Malfunction:	Possible causes:	Remedy:
Petrol Engine:		
Gasoline engine operates irregularly	- Controller linkage dirty, caught	Clean governor linkage
Benzin-Motor geht in Stoppstellung nicht aus	- Motor stop line defective - Missing sizes	Cable and connectors Check the ground contact
Benzin-Motor Zu wenig Leistung	- Air filter dirty - Cylinder head gasket loose or Seal damaged - Too little compression	Clean or replace the air filter Tighten cylinder head gasket or Renew gasket Have engine checked
E-Start Equipment:		
E-Starter it does not work	- Battery empty - Fuse defective - Defect on the wiring harness, electric starter	Charge or replace the battery Replace fuse Check wiring harness and electric starter

Malfunction:	Possible causes:	Remedy:
Drive:		
Machine moves on one side to the left or to the right	<ul style="list-style-type: none"> - Different tire pressures - Radmotore Wheel motors are worn - Wheel hub started - Valve levers are not on the end stop - Wheel fork (s) of the attachment - Can be difficult to turn 	<p>Check tire pressures and, if necessary, pump up</p> <p>Leakage amount at both wheel motors determine. Dodge these too much from both</p> <p>Renew wheel motors.</p> <p>Seat of the hydraulic motor and wheel hub check and replace if necessary.</p> <p>Castellated nut with impact wrench</p> <p>Pull and thread with Loctite first</p> <p>Provided</p> <p>Check Bowden cables for ease of movement and if necessary oil or renew,</p> <p>Check the stroke of the Bowden cables and, if necessary, readjust</p> <p>Lubricate all wheel forks, so this easy to turn.</p>
Machine loses in driving performance	<ul style="list-style-type: none"> - V-belt of axial piston pump not sufficiently tensioned - Pump builds up too little pressure (pump gets louder or yells) - Pump builds up too little pressure (pump gets louder or yells) - Oil temperature too hot - Oil temperature too hot for machine with oil cooler - Bypass valve is not closed properly ge-schlossen - Oil filter dirty - Oil Leak 	<p>Check the V-belt tension, replace the V-belt if it is burnt or the V-belt tensioner is at the end stop</p> <p>Renew pump</p> <p>Check oil quantity in hydraulic oil tank and top up if necessary</p> <p>Check oil quantity in hydraulic oil tank and top up if necessary</p> <p>Clean oil cooler (see Maintenance), fan to check function, thermostat kontrollieren control (switch-on temp 60 °C),</p> <p>Check fuse, check cables or connectors</p> <p>Close the bypass valve on the steering valve</p> <p>Renew oil filter in hydraulic oil tank (pay attention to cleanliness)</p> <p>Check hydraulic connections for leaks</p>
Powertrain:		
V-belts slip through	<ul style="list-style-type: none"> - V-belt tension too weak due to insufficient preload by the tension spring - Flanks of the V-belts are hard and cracked - Attachment is blocked - External flail knife has stuck between the flail shaft and the side plate of the flail casing (only applies to Flail mower and Rough Cutter) 	<p>Determine length change of tension spring (see chapter "Maintenance") and adjust the stroke of the Bowden cable</p> <p>Replace the V-belt, burned</p> <p>Attachment to foreign objects examine and remove if necessary</p> <p>Relieve knife from predicament</p>

14 EG – Konformitätserklärung
CE Déclaration de conformité
EC Declaration Conformity
EG conformiteitsverklaring

D

Wir

F

Nous

GB

We

NL

Wij

Kersten Arealmaschinenn GmbH
Empeler Straße 95
D- 46459 Rees

erklären, dass das
Produkt

déclarons que le

herewith declare
produit

verklaren dat het
that the product

Einachsschlepper

Porte-Outils

Tool Carrier

Werktuigdrager

UBS Master 18 G - GE

mit allen einschlägigen
Bestimmungen der
EG-Maschinenricht-
linie 2006/42/EG in
Übereinstimmung ist.

satisfait à l'ensemble
de la directive machines
2006/42/CE.

fulfiles all relevant
provisions of Directive
2006/42/EC.

voldoet aan alle
toepasselijke be-
palingen van EG-
Machinerichtlijn
2006/42/EG.

Die Maschine ist auch
in Übereinstimmung
mit allen einschlägigen
Bestimmungen der fol-
genden EG-Richtlinien:

Cette machine satisfait
également à toutes les
dispositions pertinentes
des directives CE
suivantes:

The machinery is also
in compliance with all
relevant provisions of
the following EC
directives:

De machine is ook
in overeenstemming
met alle toepasselijke
bepalingen van de vol-
gende EG-richtlijnen:

Weiterhin wurden fol-
gende Normen ange-
wendet:

En outre, les normes et
spécifications techniques
suivantes ont été utilisées:

The following
harmonised standards
apply:

Volgende geharmoni-
seerde normen warden
gehanteerd:

DIN EN 12733
EN ISO 12100 : 2010

Herr

Monsieur

Mr.

De heer

Dipl. Ing. (FH) Robert Bosch
Empeler Straße 95
D-46459 Rees

ist bevollmächtigt
die technischen Unter-
lagen zusammenzu-
stellen.

est autorisé à constituer
la documentation
Technique conformément
à l'annexe VII A.

is authorised to
compile the technical
file according to Annex
VII A.

is gemachtigd het
technische dossier
samen te stellen.

Rees, 28.04.2014

R. Bosch

Geschäftsführer

Directeur

Managing Director

Bedrijfsleider

Kersten

SITE MAINTENANCE EQUIPMENT

Distributed in UK by
Kersten (UK) Ltd Tel. 0118 986 9253

Progress House
39 Boulton Road Reading, RG2 0NH
www.kerstenuk.com - info@kerstenuk.com